

TM-11-5815-365-14-2  
NAVELEX 0967-245-8010  
TO 31W4-2FG-1351-2

**BULLETIN 295B**

**TECHNICAL MANUAL**

**MOTOR UNITS**

**(MU, LMU AND YMU)**

**(A MODEL)**

This publication replaces all previously dated Army and Navy manuals, and the Air Force To 31W4-2FG-1351 Vol 2 of 6 dated 1 October 1969.

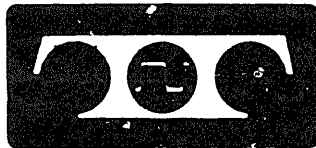

**TELETYPE®**  
**CORPORATION**

8888 TOWHY AVENUE, SKOKIE, ILLINOIS

**MARCH 1972**

TM-11-5815-365-14-2  
NAVELEX 0967-245-8010  
TO 31W4-2FG-1351-2

**REPRINTED BY COURTESY OF THE TELETYPE CORPORATION.  
(Reprinted by FMC-98230, MARCH 1972)**

**BULLETIN 295B**

**TECHNICAL MANUAL**

**MOTOR UNITS**

**(MU, LMU AND YMU)**

**(A MODEL)**

**This publication replaces all previously dated Army and Navy manuals, and the Air Force To 31W4-2FG-1351 Vol 2 of 6 dated 1 October 1969.**



**TELETYPE®  
CORPORATION**

8888 TOWHY AVENUE, SKOKIE, ILLINOIS

**MARCH 1972**

## INTRODUCTION

**Bulletin 295B is a technical manual that provides descriptive and maintenance information for the Motor Units.**

**The bulletin is made up of a group of appropriate independent sections. They are separately identified by title and section number, and the pages of each section are numbered consecutively, independent of other sections. The identifying number of a section, a 9-digit number, appears on each page of the section, in the upper left corner of left-hand pages and the upper right corner of right-hand pages.**

**To locate specific information, refer to the table of contents. Find the name of the involved component in column one and the title of the section in column two. The correct 9-digit section will then be found in column three. The sections are arranged in the order shown in the table of contents. Turn to page one of the section indicated where the contents of that section will be found (except where a section is small and does not require a listing of contents).**

**The sections comprising this bulletin are stocked separately and may be ordered individually if the entire bulletin is not required.**

## TABLE OF CONTENTS

Equipment	Contents	Section	Issue
<b>Motor Units</b>	<b>Description and Principles of Operation</b>	570-220-100TC	<b>4</b>
<b>Motors and Motor Units</b>	<b>Requirements and Adjustments</b>	570-220-700TC	<b>5</b>
<b>Motor Units</b>	<b>Lubrication</b>	570-220-701TC	<b>5</b>
<b>Motor Units</b>	<b>Disassembly and Reassembly</b>	570-220-702TC	<b>1</b>
<b>Motor Units</b>	<b>Parts</b>	570-220-800TC	<b>4</b>

**MOTOR UNITS**

**DESCRIPTION AND PRINCIPLES OF OPERATION**

CONTENTS	PAGE
1. GENERAL .....	1.
2. DESCRIPTION .....	2
<b>SYNCHRONOUS MOTOR UNITS</b> ....	1
A. Miniature Synchronous Motor Units .....	1
B. Standard and Heavy Duty Synchronous Motor Units .....	2
<b>SERIES GOVERNED MOTOR UNITS</b> .....	3
A. 1/20 Horsepower Motor Units (AC/DC and AC Only) .....	3
B. 1/20 Horsepower Motor Units Variable Speed (AC/DC and AC Only) .....	4
C. 1/15 Horsepower Motor Units (AC/DC and AC Only) .....	5
D. 1/15 Horsepower Motor Units (DC) .....	5
3. PRINCIPLES OF OPERATION .....	13
<b>SYNCHRONOUS MOTOR UNITS</b> ....	13
<b>SERIES GOVERNED MOTOR UNITS</b> .....	15
<b>SERIES GOVERNED MOTOR UNITS VARIABLE SPEED</b> .....	17

1, GENERAL

1.01 This section provides description and principles of operation for motor units. It is reissued to include additional information on synchronous, series governed, and series governed variable speed motor units. Since it is a general revision, marginal arrows that indicate changes and additions have been omitted.

1.02 The motor units that provide electro-mechanical rotating motion for operating various teletypewriter apparatus are of two basic types: synchronous and series governed. Both types are self-contained motor units, with characteristics adaptable for use with standard power sources.

1.03 The synchronous type motor units (Figures 1, 2, and 3) are available in miniature (25 millihorsepower), standard, and heavy duty ratings. These motor units must be operated from a standard, single-phase, regulated power source with specifications as listed in Tables A and B.

1.04 The series governed type motor units (Figure 4) are available in standard and heavy duty horsepower ratings and may be operated from regulated or unregulated, standard, single-phase power sources, or dc (direct current). The series governed type motor unit is also available for operation with 48 volts dc only. Specifications are given in Tables C, D, and E.

2. DESCRIPTION

2.01 In general, the synchronous motor units consist of a motor and mounting arrangement, and the required starting and protective devices. Variations of this type are described below.

**SYNCHRONOUS MOTOR UNITS**

A. Miniature Synchronous Motor Units (Figure 1)

2.02 The 25 millihorsepower miniature synchronous motor units consist of a two-pole wound stator and two end shields that support a squirrel cage type rotor. The motor is secured to its bracket-type cradle by means of resilient mounts at each end, which tend to reduce the transmission of vibrations from the motor to the driven apparatus. A starting relay, capacitor and thermostatic cutout switch are mounted under the cradle. The thermostatic

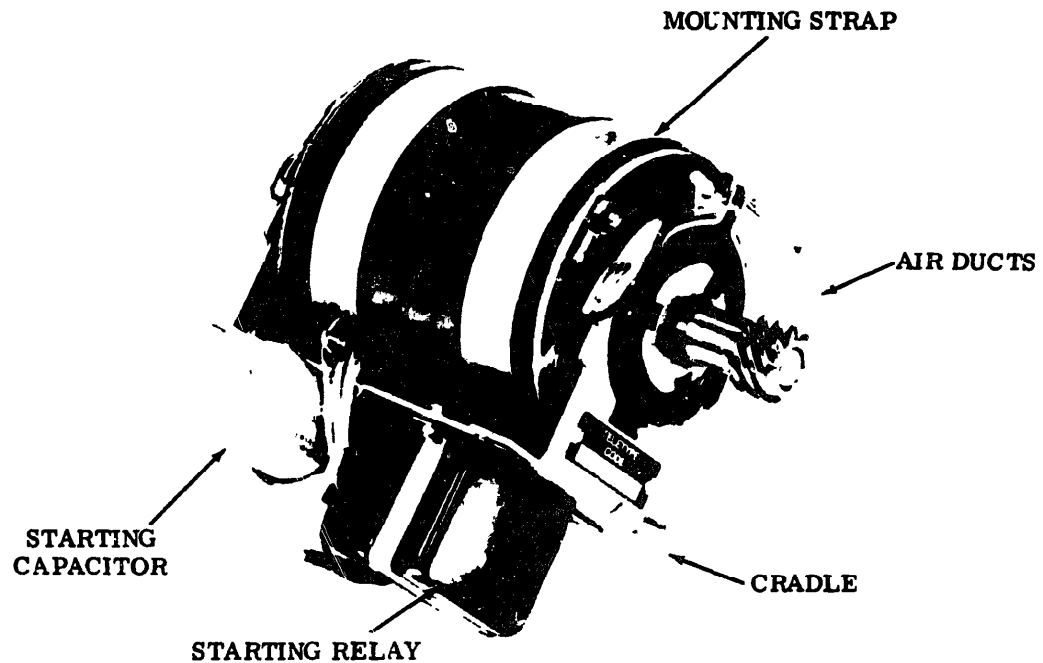

Figure 1- Typical Miniature Synchronous Motor Unit

cutout switch protects the motor windings from excessive current drawn by the motor. It can be reset manually.

2.03 The variations of the miniature synchronous include 3600 rpm (60 hertz units) and 3000 rpm (50 hertz units) operation; an external fuse instead of the thermostatic cutout switch; single or dual air ducts to improve ventilation, or an air shield to isolate the incoming cool air from the outgoing heated air; and mounting of control parts on the side of the motor instead of under the cradle.

**B Standard and Heavy Duty Synchronous Motor Units**

2.04 The standard and heavy duty synchronous motor units (Figure 2) consists of a two-pole wound stator and two end shields that support a ball bearing rotor. A combination handwheel and fan (new-style handwheel and fan is made of plastic — Figure 3) is mounted on the motor shaft, and two fans are mounted at each end of

the rotor within the end shields. The opposite end of the shaft contains a tapped hole for mounting the driving gear. A motor starting relay, starting capacitor, and thermostatic cutout switch are mounted in a compartment of the motor mounting bracket. The thermostatic cutout switch, which is reset manually, protects the motor winding from excessive current drawn by the motor. The motor is supported by resilient mounts which are part of the end shields and which are held in place by straps attached to the mounting bracket. The resilient mounts tend to reduce the transmission of vibration from the motor to the driven associated apparatus.

2.05 Variations of the standard and heavy duty synchronous motor units include: 3600 rpm (60 hertz units) and 3000 rpm (50 hertz units) operation; 1/20 and 1/12 horsepower ratings; replacement of the fan with a gear to reverse the direction of rotation for such applications as the high speed punch unit; inverted mounting for installation in the Wall Mounted Page Printer Set, for example; re-location of control parts to meet varying installation re-

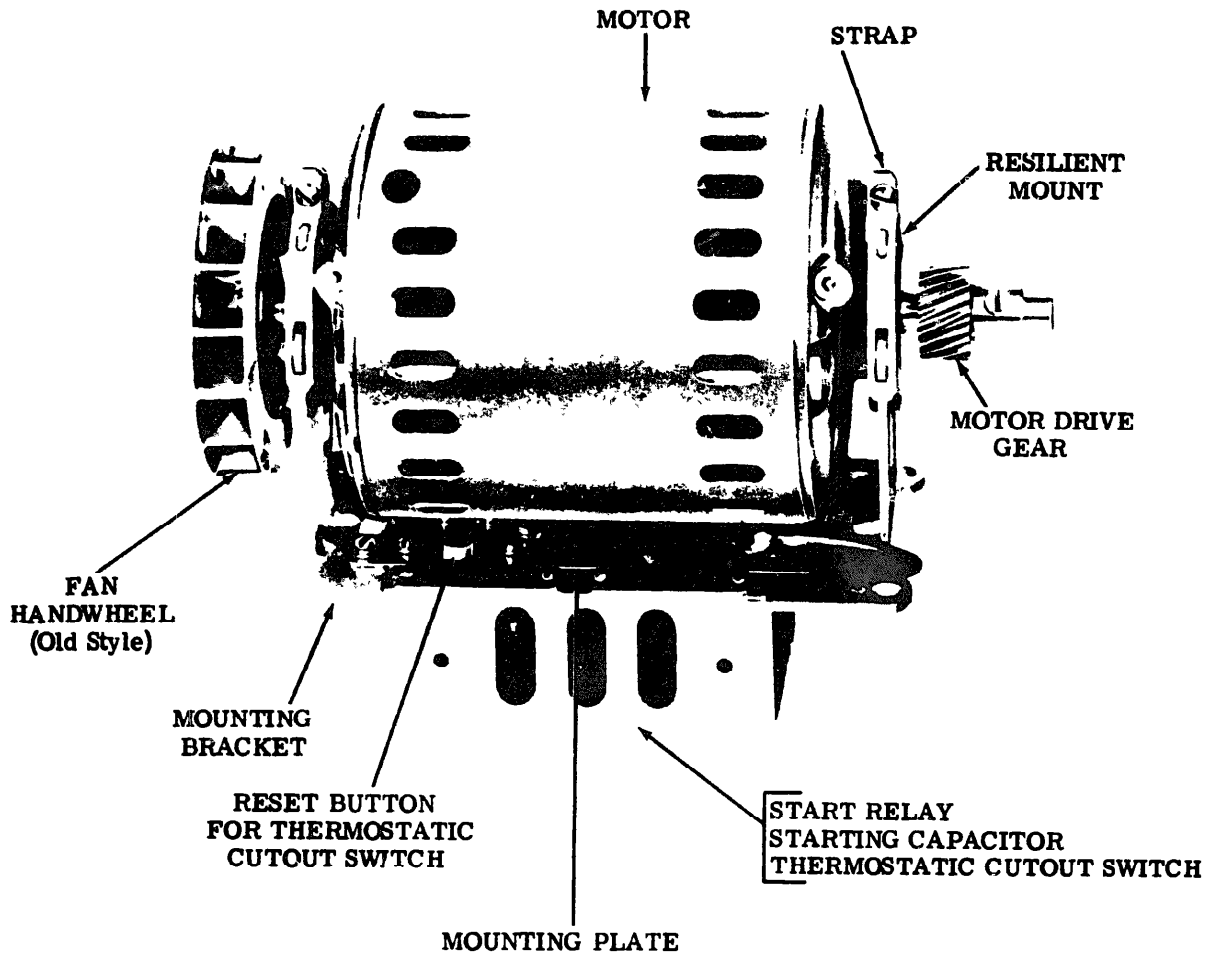

Figure 2- typical Standard or Heavy Duty Synchronous Motor Unit

quirements as in the Multiple KSR and RO Set where the control parts are mounted in a compartment at the rear of the fan. Some standard and heavy duty synchronous motor units have the start relay and start capacitor held in position with springs by hooking the ends of the springs through the projections in the sides of the mounting bracket.

SERIES GOVERNED MOTOR UNITS (Figure 4)

2.06 The series governed motor units typically consist of a motor, speed regulator (governor), protective and control devices, and a mounting. Variations of this type are described below.

A . 1/20 Horsepower Motor Units (AC/DC and AC Only)

2.07 The 1/20 hp series governed motor unit consists of a series type motor, speed governor, motor mounting bracket, and a housing for the governor resistors and spark suppression capacitor. The governor is mounted on an extension of the armature shaft and includes a fan that circulates air through the motor. The opposite end of the shaft contains a tapped hole for mounting the driving gear. Targets for speed checking purposes are provided on the governor cover. The motor is mounted by means of resili-

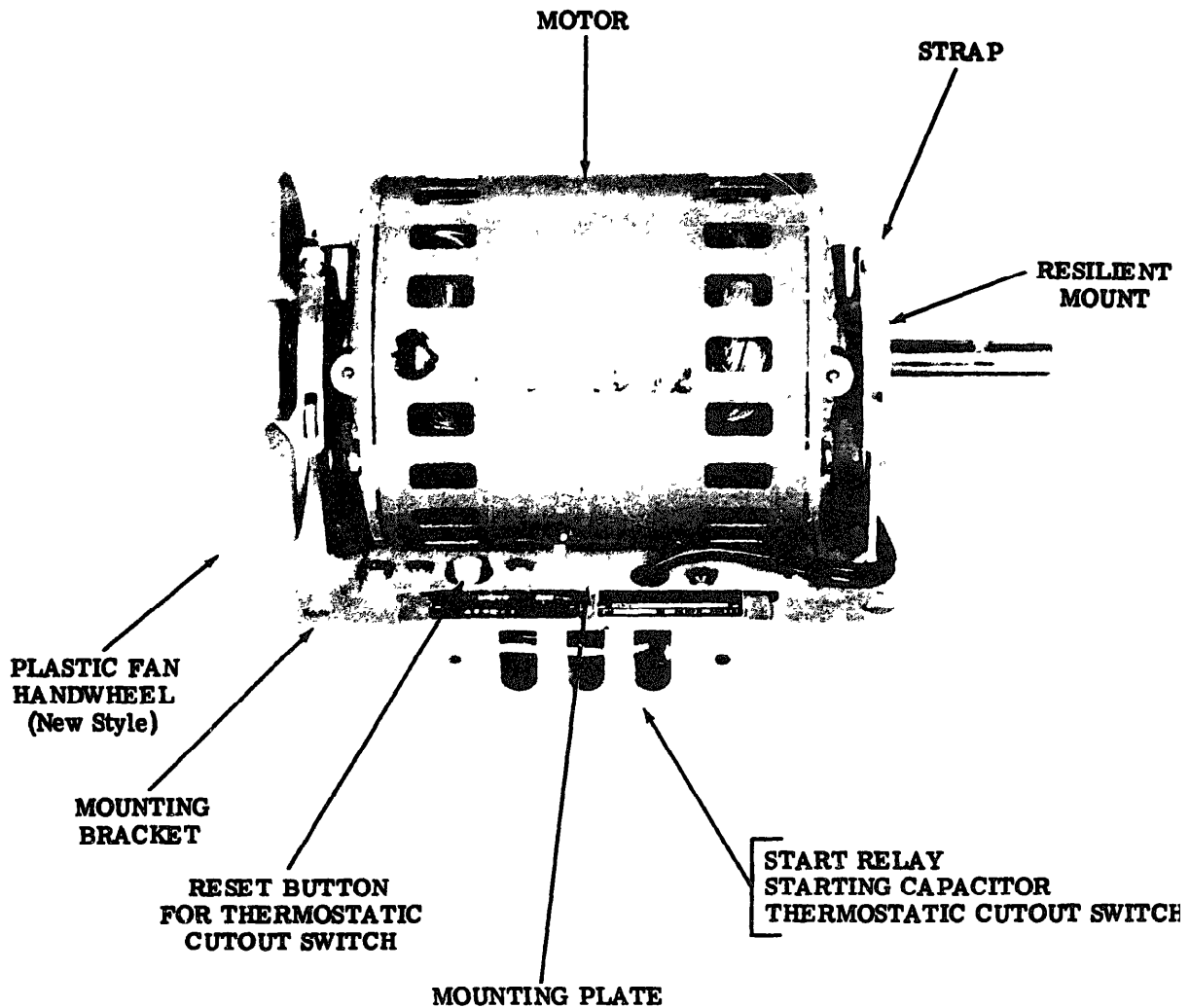

Figure 3. Typical or Heavy Duty Synchronous Motor Unit  
With New-Style Plastic Handwheel

ent mounts at each end shield that are fastened to the mounting bracket by straps. The ac only motor unit is furnished with a bidirectional switch controlled governor.

2.08 A variation of the motor unit described in 2.07 is available with electrostatic shielding and radio frequency noise suppression.

B . 1/20 Horsepower Motor Units Variable Speed (AC/DC and AC Only)

2.09 These motor units are similar to the units described in 2.07 and 2.08 but have a gear arrangement permitting changing the motor speed manually while the motor is in operation. The ac only motor unit is furnished with a bidirectional switch controlled governor.



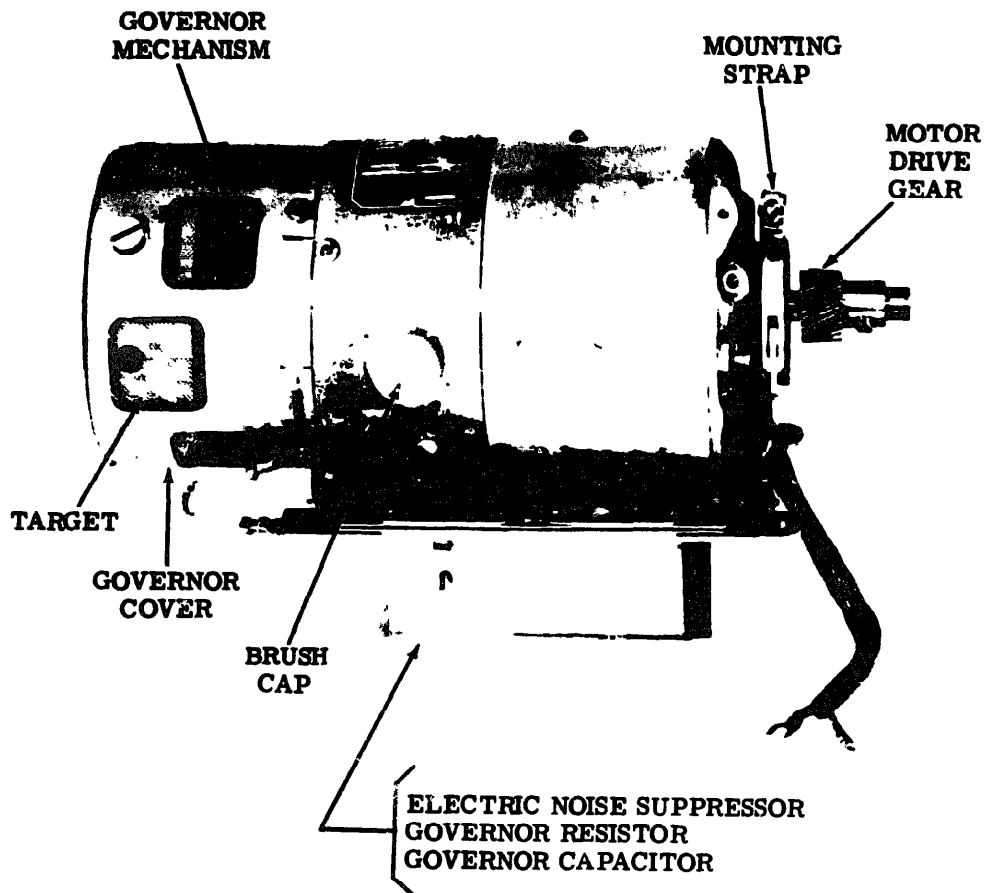

Figure 4- Typical Series (Governed) Motor Unit

**C . 1/15 Horsepower Motor Units (AC/DC and AC Only)**

2.10 These motor units are similar to the units described in 2.07, but are equipped with electrostatic shielding and radio frequency noise suppression. The ac only motor unit is furnished with a bidirectional switch controlled governor.

The higher horsepower rating accommodates, for example, the requirements of the Automatic Send-Receive Set.

**D . 1/15 Horsepower Motor Units (DC)**

2.11 These motor units are designed to operate with 48 volts dc only and are equipped with electrostatic shielding and radio frequency noise suppression.

TABLE A  
TECHNICAL CHARACTERISTICS OF MINIATURE SYNCHRONOUS MOTOR UNITS

CHARACTERISTICS	LMU19, LMU20, LMU24, LMU26, LMU31, LMU45, MU43, LMU56	LMU35
<b>Rated Horsepower</b>	25 Millihorsepower	25 Millihorsepower
<b>Input Voltage</b>	115 ±10% AC	115 ±10% AC
<b>Phase</b>	Single	Single
<b>Frequency</b>	60 hertz, ±0.75%	50 hertz, ±1%
<b>Input Current (Full Load - Amperes)</b>		
Starting	5.0	3.0
Running	1.25	0.47
<b>Power Factor (Full Load)</b>	56%	89%
<b>Watts Input (Full Load)</b>	76	50
<b>Start Capacitor</b>	88-108 UF	64-77 UF
<b>Run Capacitor</b>	-	7.0 UF
<b>Speed</b>	3600 RPM	3000 RPM
<b>Rotation</b>	Clockwise viewed from pinion end	Clockwise viewed from pinion end
<b>Mounting</b>	Upright	Upright
<b>Other Distinguishing Characteristics</b>	<p>LMU19 - Relay, capacitor, and thermostatic cutout switch mounted on motor bracket.</p> <p>LMU20, LMU26 - Relay, capacitor, and thermostatic cutout switch mounted on motor bracket. LMU20 has a ventilator bracket, LMU26 none.</p> <p>LMU24 - Twin exhaust ducts. Relay and capacitor mounted on motor bracket. No thermostatic cutout switch. Fused externally. Latest design have double shaft.</p> <p>LMU31 - Capacitor and thermostatic cutout switch mounted on motor bracket. Relay mounted on bracket assembly.</p> <p>LMU45, MU43 - Relay, thermostatic cutout switch mounted on motor bracket. Capacitor mounted on motor shield. Wiring for external start switch noise suppressor (LMU45 only).</p> <p>LMU56 - Has double shaft. Similar to LMU24 except no ventilator brackets.</p>	<p>LMU35 - Contains no thermostatic cutout device. Fused (0.8A) externally. Relay and capacitors mounted on motor mounting bracket. Equipped with a ventilator bracket and bidirectional switch.</p>

TABLE B  
 TECHNICAL CHARACTERISTICS OF STANDARD AND HEAVY DUTY SYNCHRONOUS MOTOR UNITS

CHARACTERISTICS	LMU3, LMU15, LMU21, LMU30, LMU37, LMU42, LMU46, LMU49, YMU2, YMU4	LMU33, LMU36, LMU38, LMU51, LMU52, LMU55, YMU3	LMU11, LMU12	LMU50
Rated Horsepower	1/20	1/20	1/12	1/12
Input Voltage	115 ±10%, AC	115 ±10%, AC (230 ±10% AC, LMU55)	115 ±10%, AC	115 ±10%, AC
Phase	Single	Single	Single	Single
Frequency	60 hertz, ±0.75%	50 hertz, ±0.75%	60 hertz, ±0.75%	50 hertz, ±0.75%
Input Current (Amperes)				
Starting	9.0, (7.0, YMU2)	8.3, (4.3, LMU55), (8.0, YMU3)	12.25	14.5
Running	1.85	2.4, (1.25, LMU55)	2.8	2.68
Power Factor (Full Load)	30%	35%	44.75%	34.4%
Watts Input (Full Load)	65, (90, YMU2), (90, YMU4)	107, (105, LMU55)	132.9	148
Heat Dissipation (Watts)	50	70	70.6	62
Start Capacitor Rating	43-52 UF	43-52 UF (15-18 UF, LMU55)	170-226 UF	161-193 UF
Speed	3600 RPM	3000 RPM	3600 RPM	3000 RPM
Rotation	LMU42 *CW, others *CCW viewed from fan or short shaft end.	CCW viewed from fan or short shaft end.	CCW viewed from fan end.	CCW viewed from fan end.
Mounting	All upright except LMU30 which is inverted.	All upright except LMU36 which is inverted.	LMU11 - Inverted LMU12 - Upright	Upright
Other Distinguishing Characteristics	LMU3 - Control parts in compartment under motor. Fan cooled. Thermostatic cutout switch.	LMU33 - Similar to LMU3. No fan.  LMU36 - Similar to LMU3 except for inverted mounting with control parts above motor.	LMU11 - Control parts located above motor for inverted mounting. Fan cooled. Thermostatic cutout switch.	Similar to LMU11 but with control parts in motor mounting cradle. Starting relay is voltage sensitive type mounted on bracket externally and attached to side of mounting cradle.

\*CW - Clockwise

\*CCW - Counterclockwise

TABLE B  
TECHNICAL CHARACTERISTICS OF STANDARD AND HEAVY DUTY SYNCHRONOUS MOTOR UNITS (Continued)

CHARACTERISTICS	LMU3, LMU15, LMU21, LMU30, LMU37, LMU42, LMU46, LMU49, YMU2, YMU4	LMU33, LMU36, LMU38, LMU51, LMU52, LMU55, YMU3	LMU11, LMU12	LMU50
<p><b>Other Distinguishing Characteristics (continued)</b></p>	<p>LMU15 - Same as LMU3 except no fan. Pinion on short shaft end.</p> <p>LMU21 - Same as LMU3 except control parts at rear of fan.</p> <p>LMU30 - Same as LMU3 except for inverted mounting with control parts above motor.</p> <p>LMU37 - Same as LMU3 except for cradle and mounting arrangement. Control parts on side of motor.</p> <p>LMU42 - Same as LMU3 except cradle and mounting arrangement and control parts are in a bracket on side of motor and has CW rotation.</p> <p>LMU46 - Same as LMU3 except for external wiring for motor start relay arc suppressor.</p> <p>LMU49 - Same as LMU3 but with speed sensing device.</p>	<p>LMU38 - Differs from LMU3 only in power frequency.</p> <p>LMU51 - Similar to LMU3 except for more compact cradle and mounting arrangement. Fan reversed (solid side adjacent to end bell).</p> <p>LMU52 - Similar to LMU3 except control parts mounted at rear of fan.</p> <p>LMU55 - Similar to LMU3 except has 230 v input.</p> <p>YMU3 - Same as YMU2 except thermo-static cutout switch for 50 hertz.</p>	<p>LMU12 - Same as LMU11 but with control parts located in motor mounting cradle and end shields rotated 180° for upright mounting.</p>	

TABLE B  
 TECHNICAL CHARACTERISTICS OF STANDARD AND HEAVY DUTY SYNCHRONOUS MOTOR UNITS (Continued)

CHARACTERISTICS	LMU3, LMU15, LMU21, LMU30, LMU37, LMU42, LMU46, LMU49, YMU2, YMU4	LMU33, LMU36, LMU38, LMU51, LMU52, LMU55, YMU3	LMU11, LMU12	LMU50
Other Distinguishing Characteristics (continued)	<p>YMU2 - Similar to LMU3 except has control parts mounted at rear of fan. Has suppressor network.</p> <p>YMU4 - Similar to LMU3 except network assembly mounted on side of mounting bracket.</p>			

TABLE C  
TECHNICAL CHARACTERISTICS OF SERIES GOVERNED MOTOR UNITS FOR  
LMU6, 13, 28, 29, 39, 41

CHARACTERISTICS	LMU6, LMU28, LMU41				LMU13, LMU39				LMU29
	25	50	60	DC	25	50	60	DC	
Rated Horsepower	1/20				1/15				1/15
Input Voltage	115 ±10%, AC/DC				115 ±10%, AC/DC				48 ±10%, DC
Phase	Single				Single				-
Frequency	25, 50, or 60 hertz, or DC				25, 50, or 60 hertz, or DC				-
Input Current (Full Load - Amperes)	Hertz				Hertz				
	25	50	60	DC	25	50	60	DC	
	Starting	2.4	2.7	1.9	1.8	4.5	4.0	2.8	3.4
Running	1.18	1.34	1.12	0.93	2.1	2.3	1.8	1.7	2.5
Power Input (Watts)	123	114	92	1.07	235	200	190	195	120
Power Factor (Full Load)	90%	74%	71%	-	96.8%	87%	79%	-	-
Heat Dissipation (Watts)	86	87	55	70	130	97.2	94.2	111	66
Series Resistor (Ohms)	25	-	-	50	12	-	-	20	-
Target Indicator	4, 6, and 35 Spot				4, 6, and 35 Spot				4, 6, and 35 Spot
Governed Speed	3600 RPM				3600 RPM				3600 RPM
Rotation	CCW viewed from commutator end				CCW viewed from commutator end				CCW viewed from governor end
Mounting	Upright				LMU13 - Inverted LMU39 - Upright				LMU29 - Upright
RF Shielding	LMU28, LMU41				LMU39				LMU29
RF Suppression	LMU28, LMU41				LMU39				LMU29
Other Distinguishing Characteristics	Control parts com- partment rectangular on LMU6, LMU28, and LMU41 governor resistor mounted on heat sink in stepped compartment.				LMU39 governor resistor mounted on a heat sink in stepped compartment. LMU13 cradle compartment is rectangular.				No screened governor cover on LMU29 with stepped com- partment.

TABLE D  
TECHNICAL CHARACTERISTICS OF SERIES GOVERNED MOTOR UNITS FOR  
LMU57, 61, 63, 64, YMU5

CHARACTERISTICS	LMU61, YMU5	LMU57, LMU63, LMU64
Rated Horsepower	1/15	1/20
Input Voltage	115 $\pm$ 10%, AC only	115 $\pm$ 10%, AC only
Phase	Single	Single
Frequency	25, 50, 60 hertz	25, 50, 60 hertz
Input Current (Full Load Amperes)	<u>Hertz</u> <u>25</u> <u>50</u> <u>60</u>	<u>Hertz</u> <u>25</u> <u>50</u> <u>60</u>
Starting	4.5   5.0   3.8	2.8   3.1   2.2
Running	2.5   2.3   2.4	1.2   1.3   1.2
Power Input (Watts)	135   130   133	82   61   63
Power Factor (Full Load)	45%   48%   54%	67%   43%   52%
Heat Dissipation (Watts)	72   72   75	53   34   36
Series Resistor (Ohms)	12   —   —	25   —   —
Target Indicator	4, 6, and 35 spot	4, 6, and 35 spot
Governor Speed	3600 RPM	3600 RPM
Rotation	CCW viewed from com- mutator end	CCW viewed from com- mutator end
Mounting	Upright	Upright
RF Shielding	LMU61, YMU5 Motor Only	LMU63, LMU64
RF Suppression	LMU61	LMU63, LMU64
Other Distinguishing Characteristics	LMU61 control parts mounted within end shield. Has bidirectional switch.  YMU5 control parts mounted within end shield. Has bidirectional switch.	LMU57, LMU63, and LMU64 have control parts mounted within end shield. LMU63 noise suppressor mounted in square con- tainer.  LMU64 noise suppressor mounted in rectangular container.  LMU57, 63, and 64 have bidirectional switch.

TABLE E  
TECHNICAL CHARACTERISTICS OF SERIES GOVERNED MOTOR UNITS FOR LMU47, 60

CHARACTERISTICS	LMU47				LMU60		
Rated Horsepower	1/20				1/20		
Input Voltage	115 $\pm$ 10%, AC/DC				115 $\pm$ 10%, AC only		
Phase	Single				Single		
Frequency	25, 50, 60 hertz, DC				25, 50, 60 hertz		
Input Current (Full Load Amperes)	Hertz				Hertz		
	<u>25</u>	<u>50</u>	<u>60</u>	<u>DC</u>	<u>25</u>	<u>50</u>	<u>60</u>
Starting	2.4	2.7	1.9	1.8	2.4	2.8	2.1
Running	1.18	1.34	1.12	0.93	1.2	1.3	1.2
Power Input (Watts)	123	114	92	107	70	70	65
Power Factor (Full Load)	90%	74%	71%	—	90%	74%	71%
Heat Dissipation (Watts)	86	87	55	70	86	87	55
Series Resistor (Ohms)	25	—	—	50	25	—	—
Target Indicator	—				—		
Governor Speed	3600 RPM				3600 RPM		
Rotation	CCW viewed from com- mutator end				CCW viewed from com- mutator end		
Mounting	Upright				Upright		
RF Shielding	LMU47				LMU60		
RF Suppression	LMU47				LMU60		
Other Distinguishing Characteristics	Variable speed control parts mounted in stepped compartment.				Variable speed control parts mounted within end shield. Noise suppressor mounted in rectangular cradle compartment. Has bidirectional switch.		



### 3. PRINCIPLES OF OPERATION

#### SYNCHRONOUS MOTOR UNITS (Figures 1, 2, and 5)

3.01 The following description of operation applies to the miniaturized, standard, and heavy duty synchronous motor units.

3.02 The stator of the synchronous motor has two windings: a starting winding and an operating (or run) winding. The starting winding, starting capacitor and the normally-open contacts of the starting relay are connected in series. The coil of the current-operated starting relay is connected in series with the operating winding. When power is applied, the initial current through the operating winding (and also the starting relay coil) energizes the relay, and its contacts close the circuit to the starting winding. As the speed of the rotor increases, the current in the operating winding decreases and, when the current has decreased to a pre-

determined magnitude, the starting relay de-energizes. Its contacts open and remove the starting winding from the operating circuit. The rotor continues to accelerate until it reaches the synchronous operating speed. Rotation is in the counterclockwise direction, as viewed from the fan or short-shaft end of the motor.

3.03 The thermostatic cutout switch is connected in series with both stator windings. This temperature operated device opens the circuit to these windings whenever excessive current is drawn, such as may occur if the motor is stalled, thereby preventing overheating and damage to the motor and control parts. The switch may be reset after the unit has cooled by depressing a pushbutton.

3.04 In some motor units a suppression network is wired in parallel with the starting winding to suppress arcing of the relay contacts (Figure 5).

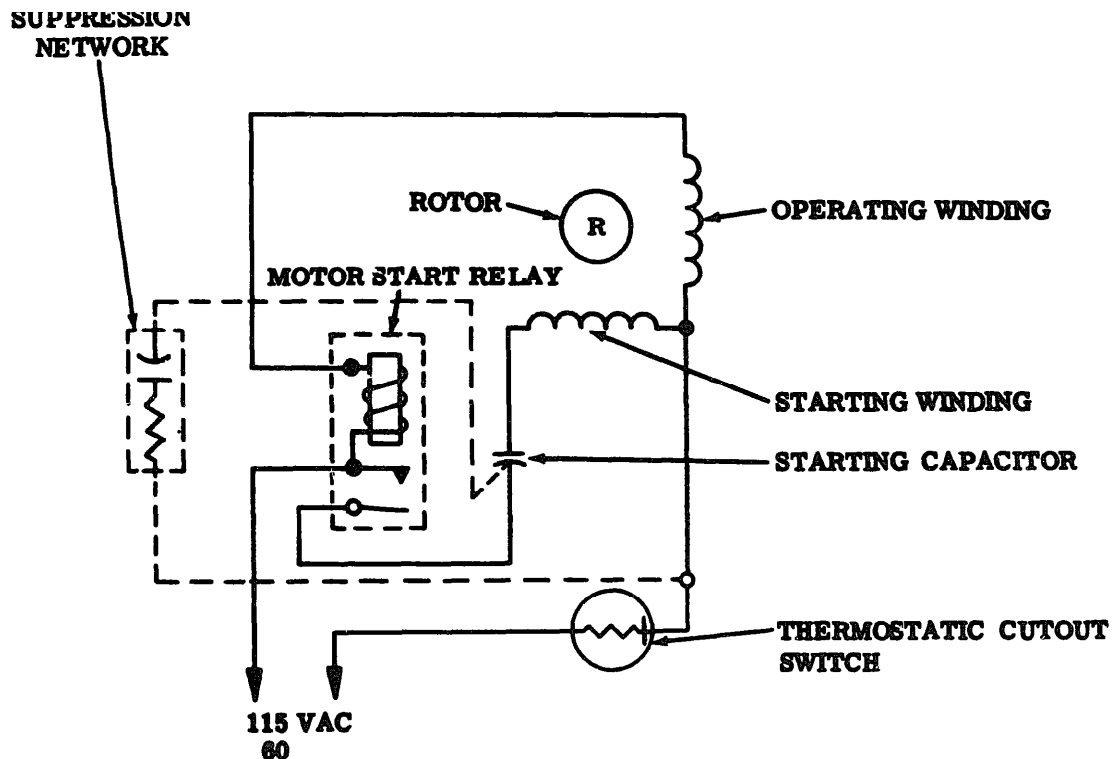

Figure 5- Typical Synchronous Motor Unit Schematic Diagram

3.05 The following description of operation applies to synchronous motors with a bidirectional switch (Figure 6).

3.06 The stator of the synchronous motor has two windings: a starting winding and an operating (or run) winding. When power is applied to the motor terminals, the initial current through the relay coil, in series with the operating (or run) winding, energizes the relay. Its contacts close applying current to the gate of the bidirectional switch through a resistor, thus

applying power to the start capacitor. As the speed of the rotor increases, current through the operating winding decreases and, when the current has decreased to a predetermined magnitude, the starting relay de-energizes. The contacts then open, breaking the flow of current supplied to the gate of the bidirectional switch, and disconnect the starting winding and start capacitor from the line. The rotor continues to accelerate until it reaches the synchronous operating speed. Rotation is in the counterclockwise direction, as viewed from the leads end of the motor.

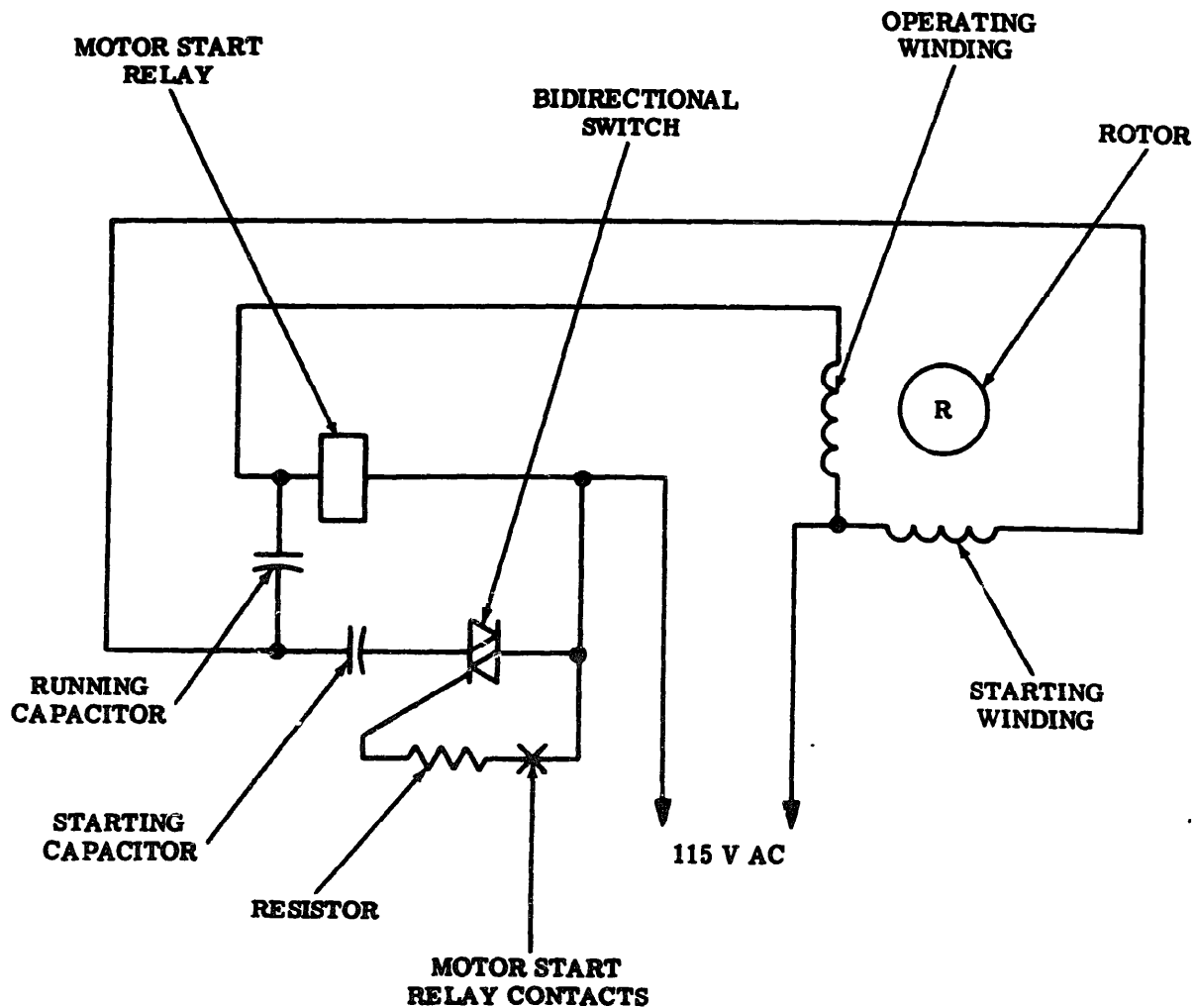

Figure 6- Typical Synchronous Motor Unit Schematic Diagram With Bidirectional Switch

**SERIES GOVERNED MOTOR UNITS**

3.07 The following description of operation is applicable to ac/dc series governed motor units Figures 3 and 7.

3.08 The series wound motor utilizes an electro-mechanical governor for speed regulation. The governor regulates the speed at 3600 rpm,  $\pm 1$  percent, by alternately increasing and decreasing the current in the series connected field windings and armature, which are also in series with a governor contact. A

resistor (high-wattage) and capacitor are connected in parallel with the governor contact. The contact is held closed under the tension of a spring which is adjusted to maintain this condition during speeds up to a predetermined rate. With the contact closed, the resistors are shorted out. When the speed of the motor exceeds the predetermined rate, the centrifugal force acting upon the contact momentarily overcomes the spring tension and the contact is opened. This removes the short from the resistors and they then appear in series with the field windings and armature, reducing their current, and consequently reducing the speed of the motor.

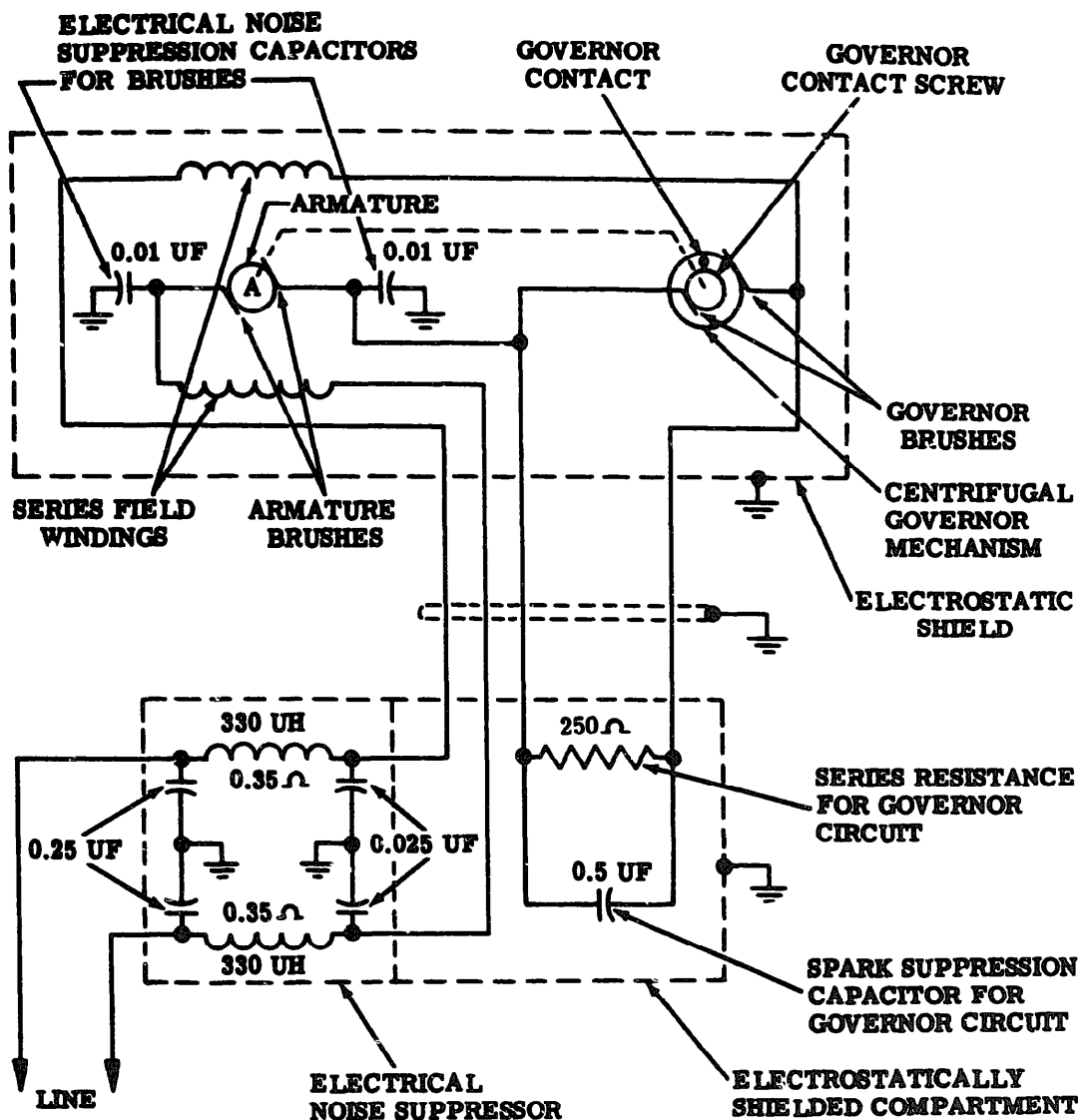

Figure 7- Typical AC/DC Series Governed Motor Unit Schematic Diagram

3.09 The tension on the contact spring is adjustable to maintain the motor speed at 3600 rpm. To make this adjustment, a target is provided to compare the motor speed with a standard. The outside surface of the governor cover is finished in white with three rows of

black spots equally spaced about its periphery. The outer, center, and inner rows contain four, six, and thirty-five spots, respectively. The four spot row is a target which should remain essentially stable at 3600 rpm, when viewed through the moving shutter of a 120 vibrations

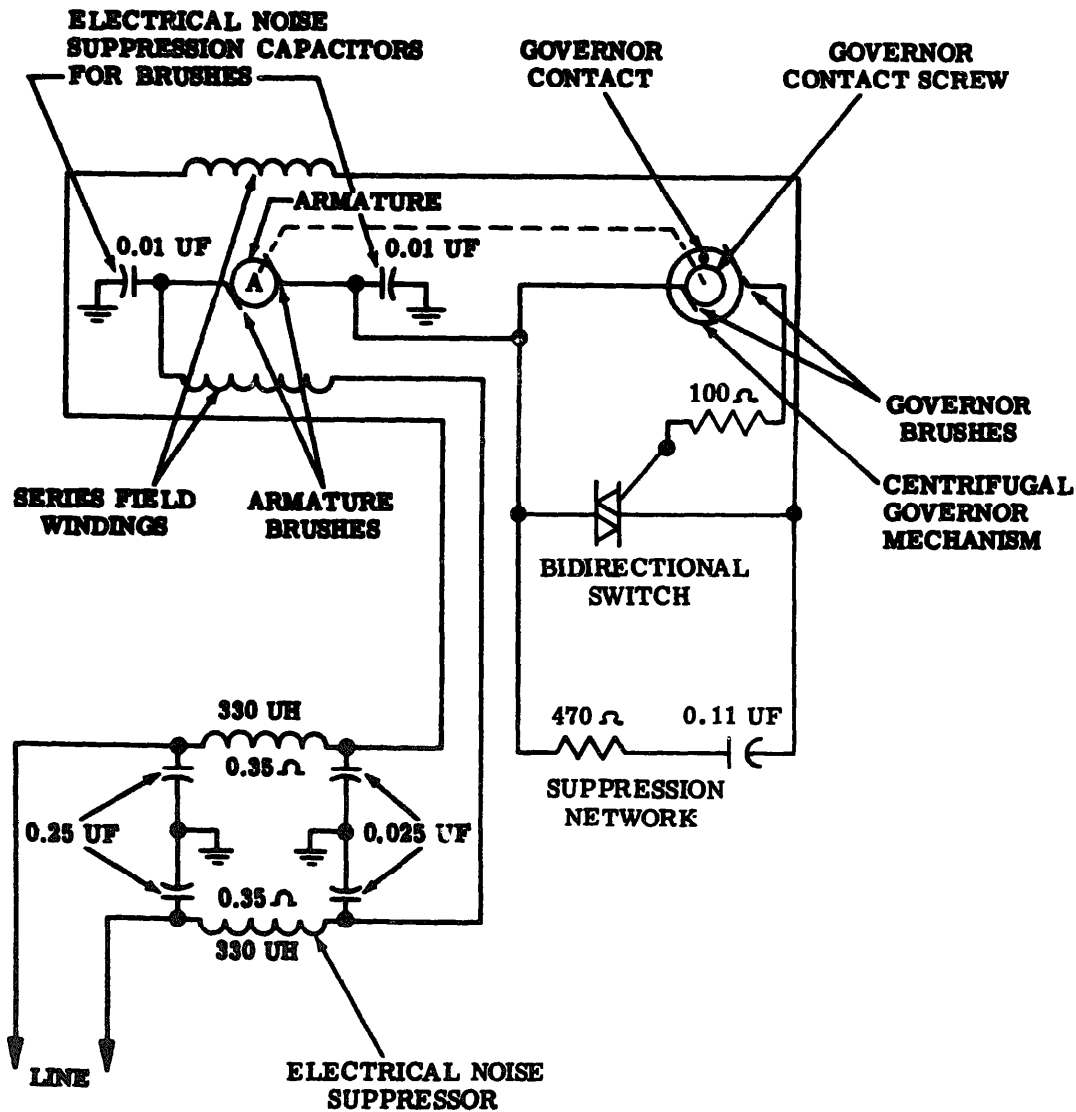

Figure 8- Typical AC Only Governed Motor Unit Schematic Diagram With Bidirectional Switch

per-second tuning fork. The six spot and thirty-five spot rows serve as targets when using an 87.5 vibration-per-second tuning fork. The six spot row is used to approach an on-speed setting and the thirty-five spot row is used to arrive at an accurate setting of 3600 rpm.

3.10 The following description of operation is applicable to ac series governed motor units furnished with a bidirectional switch (Figure 8).

3.11 The series wound motor utilizes an electromechanical governor for speed regulation. The governor regulates the speed 3600 rpm  $\pm 1$  percent by alternately increasing and decreasing the current in the series connected field windings and armature, which are also in series with a bidirectional switch controlled by the governor contacts. Normally the governor contact spring holds the governor contact against the contact screw. When the speed of the motor exceeds a predetermined rate, the centrifugal force developed on the governor contact overcomes the pull of the governor spring, and the governor contact opens, removing the trigger of the bidirectional switch, and therefore, decreasing the speed of the motor. The switch will then go into and remain in the blocking or non-conducting state when the alternating current crosses the zero reference point. Therefore, no power is applied to the motor until such time that the contacts again close and gate triggers the switch back into the conducting state. This will occur for either polarity of applied voltage. For motor speed adjustments see 3.09.

#### **SERIES GOVERNED MOTOR UNITS VARIABLE SPEED**

3.12 The variable speed motor units are not equipped with governor control linkage, tachometer, or gears. The parts are supplied in modification kit TP173518.

3.13 The variable speed motor has a range of 1800 to 4150 rpm and can be adjusted to within  $\pm 1$  percent of a specific speed while the motor is running. In this externally controlled governor, the adjusting screw is turned by a gear train actuated by the rotation of the motor. The gear train at its driven end is divided into two branches with an odd number of gears (three) in one branch and an even number of gears (four) in the other. This provides for turning the adjusting screw in either direction to increase or decrease the tension of the governor spring. The pinion of each branch of the gear train is located on the same center as the motor shaft. The pinions are part of the brake disc assembly; an assembly which is free to idle on the stud to which it is mounted. When the speed is not being changed the gears do not rotate but merely revolve with the governor on which they are mounted. However, if a brake shoe is moved against either brake disc, by operating the lever SLOW or FAST that brake disc and its associated pinion turn the spring tension and adjusting screw. Changing of the spring tension causes the motor speed to change. For governor operation for ac/dc motor units refer to 3.08. For motor units operating on ac (with bidirectional switch) refer to 3.09.

**MOTORS AND MOTOR UNITS**  
**REQUIREMENTS AND ADJUSTMENTS**

CONTENTS	PAGE	CONTENTS	PAGE
1. GENERAL .....	1	<b>Motor positioning</b> .....	18
		<b>Motor shield</b> .....	19
2. REQUIREMENTS AND ADJUSTMENTS- OTHER THAN 28, 35, AND TYPE MOTOR UNITS.....	2	<b>Standard and Heavy Duty Synchronous Motor Units</b>	
<b>Common Requirement</b> .....	2	<b>Centrifugal switch</b> .....	22
<b>Governors</b>		<b>Motor adjusting stud</b> .....	21
<b>Adjusting-wheel friction washer (single-speed governor)</b> .....	8	<b>Motor positioning</b> .....	21
<b>Center-contacting-type Governors</b> .....	9	<b>Series Governed Motor Units</b>	
<b>Edge-contacting-type Governors</b> .....	14	<b>Governor brush spring</b> .....	24
<b>Governor contacts</b> .....	7	<b>Governor contact</b> .....	23
<b>Speed-adjusting-lever stop plate</b> .....	8	<b>Governor contact backstop</b> .....	23
<b>Governed Motors</b>		<b>Motor positioning</b> .....	23
<b>Cleaning brush and brush holder</b> .....	6	<b>Motor speed</b> .....	24
<b>Commutator</b> .....	6	<b>Series Governed Variable Speed Motor Units</b>	
<b>Motor bearings</b> .....	7	<b>Brake shoe slide</b> .....	25
<b>Motor brush</b> .....	5	<b>Governor spur gear train</b> ...	26,27
<b>Motor-brush spring</b> .....	5	<b>Speed control linkage bearing plate</b> .....	25
<b>Refacing motor brush</b> .....	6	<b>Plastic Type Axial Fan for Models 28 and 35 Teletypewriter Sets</b>	
<b>Synchronous Motors</b>		<b>Cable clamp interference</b> ...	28
<b>Three-brush starting switch on G. E. motor</b> .....	3		
<b>Three-brush starting switch (Old-style on H. C. motor)</b> .....	4	1. GENERAL	
3. REQUIREMENTS AND ADJUSTMENTS 28, 35, AND 37 TYPE MOTOR UNITS .....	18	1.01 This section contains the requirements and adjustments for motors and motor units used with various teletypewriters and associated apparatus. This section and the section covering general teletypewriter requirements and adjustments provide the information necessary for maintenance of motors and motor units. It is reissued to change the title and to include the requirements and adjustments for the 14, 15, 19, and 20 type motor units, variable speed	
<b>Miniaturized Synchronous Motor Units</b>			
<b>Air ducts</b> .....	20		
<b>Capacitor position</b> .....	20		
<b>Motor gear</b> .....	18		

series governed motor units, centrifugal switch, and plastic type axial fan. Since this a general revision, marginal arrows used to indicate changes and additions have been omitted.

1.02 Also included in this section are the requirements and adjusting procedures for the maintenance of motors, motor units, and governors used with 28, 35, and 37 teletypewriter apparatus.

1.03 Routine maintenance of a motor unit is ordinarily confined to wiping oil, grease, and dust from its exterior portions. If it becomes necessary to dismantle the motor unit, consideration should be given to substituting a new motor, since motor repair and maintenance can be done more efficiently in a repair shop than on the subscriber's premises.

1.04 The figures in this section show the adjusting tolerances, positions of moving parts, and spring tensions. For requirements and procedures for adjusting the relationship between the motor pinion and the gear, refer to the particular section for the type of apparatus involved.

**CAUTION: THE ELECTRIC POWER SHALL BE DISCONNECTED BEFORE THE APPARATUS IS REMOVED FROM ITS PROTECTIVE HOUSING. WHERE OPERATION OF THE APPARATUS AFTER ITS REMOVAL FROM THE HOUSING IS REQUIRED, POWER SHALL BE APPLIED WITH APPROPRIATE PRECAUTIONARY MEASURES TAKEN TO PREVENT ACCIDENT.**

1.05 The cleaning materials specified in this section are those listed in the section covering the general requirements for cleaning teletypewriter apparatus.

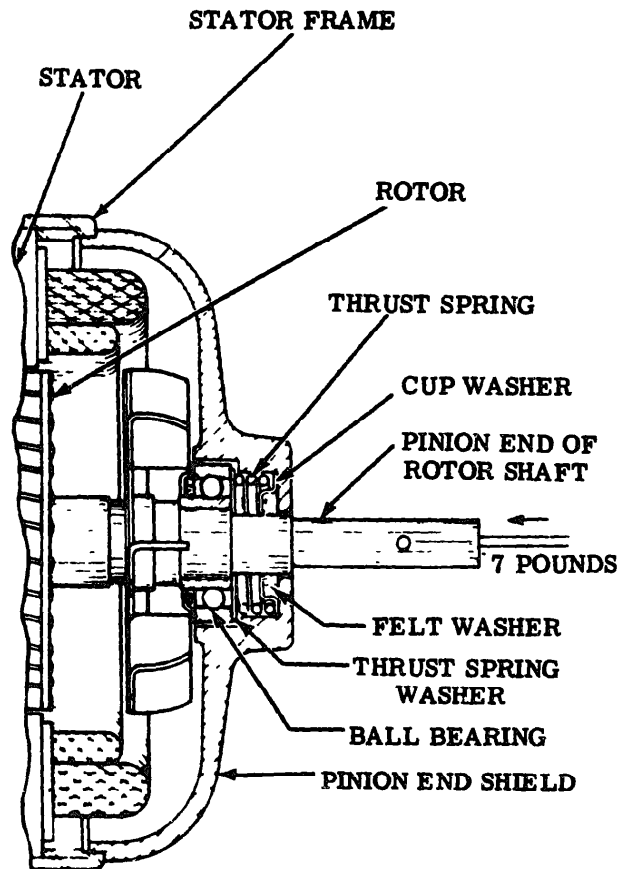

Figure 1- Rotor Thrust Spring Tension

2. REQUIREMENTS AND ADJUSTMENTS-  
OTHER THAN 29, 35, AND 37 TYPE MOTOR  
UNITS

2.01 Common Requirement - Rotor Thrust-  
spring Tension: It shall require at least  
7 pounds to push the shaft endwise. Upon re-  
leasing the tension, the shaft should return to  
its normal position. (See Figure 1.)

**Note:** All General Electric motors have  
thrust springs, but some Holtzer-Cabot mo-  
tors do not.

(a) To gauge, remove the motor from the  
teletypewriter and place the push end of  
the 15 pound scale against the switch end of

the rotor shaft and apply the pressure in line  
with the shaft.

(b) If springs do not meet this requirement,  
remove the pinion end shield and clean the  
bearing housing. If necessary, replace the  
spring. Reassemble the end shield.

2.02 Synchronous Motors;

**Note:** These requirements need not be  
checked unless there is reason to believe the  
starting switch is causing trouble or the  
motor is disassembled for other reasons.

(a) Three-brush Starting Switch on G. E.  
Motor (See Figure 2): To disassemble,

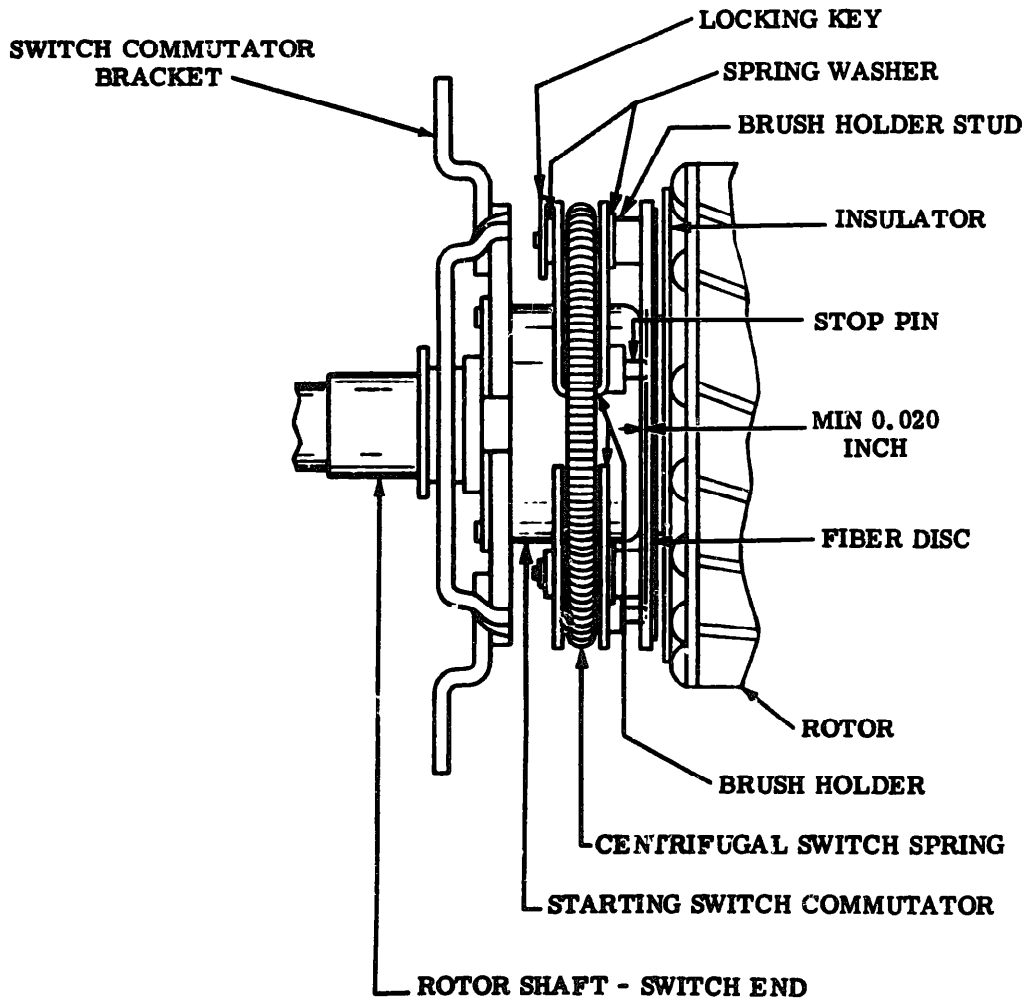

Figure 2- Three-brush Starting Switch on G.E. Motor



detach motor from its associated apparatus, and remove pinion, motor fan (if provided), and the end shield on the starting-switch end of the motor. Pull out the rotor until the starting switch is easily accessible. Unhook and remove the centrifugal-switch spring.

(1) Brush holders shall be mounted by their center mounting holes with their spring washers and locking keys securely in place, and shall be free from bind.

(2) Brush-holder stop pins shall be safely within the elongated holes of the fiber disc on which the brush holders are mounted (minimum 0.020 inch), when all the play has been taken up to reduce the engagement to a minimum. Gauge by eye.

(3) Centrifugal-switch Spring Tension: It shall require minimum 1-3/4 ounce, maximum 2 ounces for 50 hertz motors, minimum 2 ounces, maximum 2-1/2 ounces for 60 hertz motors to extend the spring to a length of 5 inches.

(4) The fiber mounting disc shall be securely fastened to the metal sleeve that secures the assembly to the rotor shaft. Loosening of the fiber disc on the metal sleeve may cause failure of the brushes to disengage from the commutator.

(5) The starting-switch commutator shall be free from excessive burns or pits and its wires securely soldered in place and in good condition.

**To Adjust:** If the commutator is burned or pitted, remove the rotor bearing, unsolder the wires attached to the commutator, and slip the commutator from the rotor shaft. Wrap a piece of 400A Aloxite around the commutator and rotate back and forth until the burned spots or pits are removed. If the burns or pits are too deep, discard the commutator. Before reassembling, make sure that the gaps between the segments of the commutator are free from metal particles and dirt.

(6) To reassemble, replace the centrifugal-switch spring, making certain that the spring eyes are fully engaged with each other. Slide the end shield on the rotor shaft and fasten the switch commutator to the end shield, tightening the screws alter-

nately, a little at a time, until both are tight. Fasten the end shield to the motor frame tightening the screws in the same manner as above.

(b) Three-brush Starting Switch (Old-style) on H.C. Motor (See Figure 3): To disassemble, detach motor from its associated apparatus, and remove pinion and motor fan (if provided). Remove the starting-switch split-ring screws, the end-shield screws, the bearing retainer screws, and the end shield. Remove the bearing-retainer screws from the pinion end shield of the motor and pull out the rotor until the starting-switch is easily accessible.

(1) Brush-arm Spring Tension: It shall require minimum 5 ounces, maximum 8 ounces, to just pull the brush arm against its stop when the brushes are resting on the commutator (split ring) and the rotor is held so that the spring being checked is in a horizontal position. Repeat check for each brush-arm spring.

(2) Brush arms shall be free and without bind, the retaining washers in place, and the end of the brush-arm mounting post safely riveted to secure the retaining washer. If retaining washers are missing or the mounting post is not safely flattened, do not attempt to flatten the mounting post but replace the assembly.

(3) The starting-switch split ring shall be free from excessive pits or burns, the gap between its segments minimum 1/32 inch and the mica insulator on its inner surface securely glued and intact. If the split ring is burned or pitted, remove the rotor bearing, unsolder the wires attached to the split ring, and slip the split ring from the rotor shaft. Wrap a piece of 400A Aloxite around the split ring and rotate back and forth until the burned spots or pits are removed. If burns or pits are too deep, the mica insulator is loose or mutilated, or the gap between the segments is less than 1/32 inch, replace the commutator. Place the split ring on the rotor shaft and reassemble the rotor bearing.

(4) Starting-switch brush-assembly mounting screws shall be tight and their fiber insulators free of breaks or cracks. Broken or cracked insulators shall be replaced.

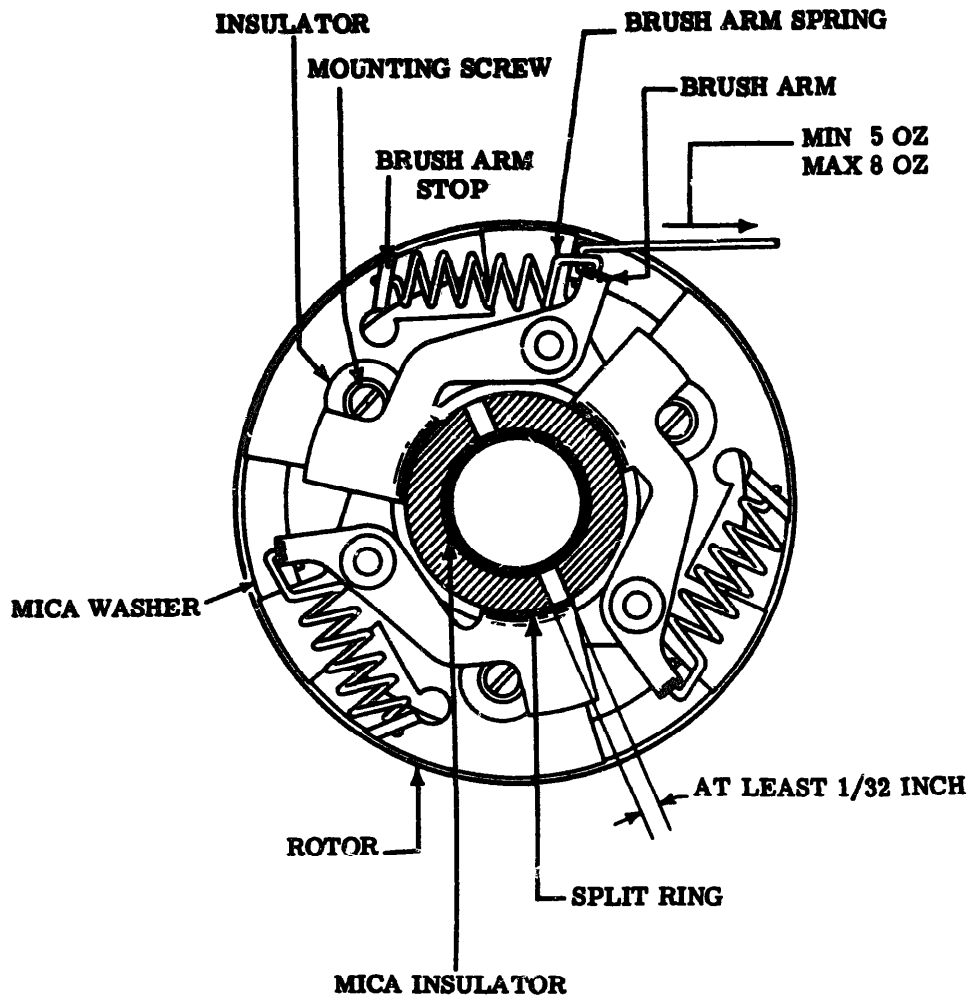

Figure 3- Old-Style Starting Switch on H.C. Motor

**Note:** The above old-style three-brush starting switch on the Holtzer-Cabot motor has been replaced by a starting switch which works by centrifugal action but employs no brushes. The installation of this newer style switch is covered in 5770S.

spring to its normal position (about 1/8 inch inside the outer edge of the insulator on the brush holder). Springs not meeting this requirement shall be replaced. Avoid the tendency to keep brush spring tension low, because it results in grooving of the collector, copper picking, and loss in brush life.

2.03 Governed Motors:

(a) **Motor-brush Spring:** Remove brush spring cap. It shall require minimum 5 ounces, maximum 8 ounces to press the motor-brush

(b) **Motor Brush (See Figure 4):** Remove the brush assembly (brush and brush spring) from its holder, noting its position and the side from which it was removed, and mark

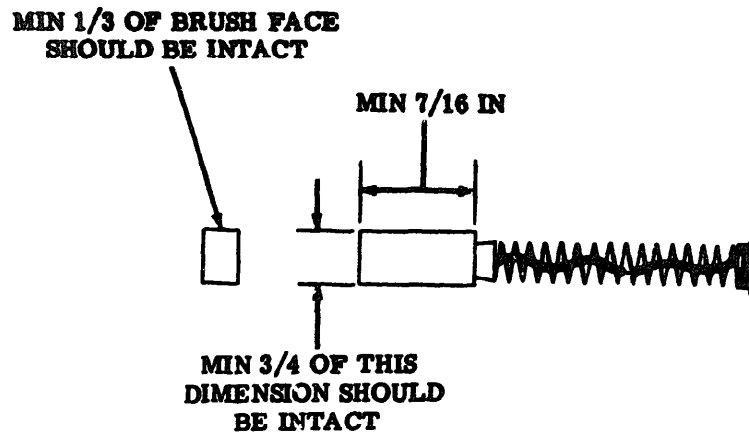

Figure 4- Motor Brush

the brush so that it may be reassembled in the same position. Where the brush has a number stamped on the carbon, this may be used as a guide in putting the brush back in place.

- (1) There shall be minimum 7/16 inch of brush material remaining, and the contact surface of the brush bearing on the commutator shall constitute minimum 1/3 of the brush face, and extend minimum 3/4 of the long dimension.
- (2) There shall be no copper pickings imbedded in the face of the brush.
- (3) Note that the stranded wire inside the brush spring is intact and free from kinks which may prevent the spring from extending properly and that the wire is securely fastened to the brush and the contact disc.

(c) **Cleaning Brush and Brush Holder:** The brush shall be wiped with a clean KS-2423 cloth dampened with KS-19578, List 1 trichloroethane. The brush holder shall be wiped out with a KS-2423 cloth dampened with KS-19578, List 1 trichloroethane and wrapped around an orange stick.

**CAUTION: USE KS-19578, LIST 1 TRICHLOROETHANE ONLY IN A WELL-VENTILATED AREA. AVOID PROLONGED OR REPEATED BREATHING OF VAPOR. AVOID PROLONGED OR REPEATED CONTACT WITH THE SKIN. USE IN SMALL QUANTITIES ONLY. DO NOT TAKE INTERNALLY.**

(d) **Refacing Motor Brush:** Where it is necessary to reface a brush, the following method shall be used: Wrap a piece of 400A Aloxite around a section of the commutator under the brush holder, with the abrasive side toward the brush. Place the brush in its proper position in the holder and put back the spring cap. Turn the armature and Aloxite back and forth by hand until the brush face has the proper curvature. The last turn shall be in the normal direction of rotation. Remove the brush and bevel the edges slightly with the Aloxite. Extreme care shall be taken to remove all traces of grit and carbon from the commutator slots and adjacent windings after the above operation. Insert the brush in its holder with the identified side up. Note that the brush slides freely, but not too loosely, in the holder.

(e) **Commutator:** A smooth, even, bronze-colored or chocolate-brown glaze is a desirable condition, and the commutator shall not be disturbed unless there is excessive sparking at the brushes under load, or unless it is noted that the commutator is grooved due to wear in excess of 0.010 inch deep, as gauged by eye. Do not attempt to remove any grooves or pits from the commutator.

- (1) **Sparking:** Not all sparking under load may be of a destructive nature. To determine whether damage is being done,

examine the commutator closely. If in doubt as to whether any marks on the commutator are caused by destructive copper etching, or are merely flecks (a carbon deposit often found on the leaving edges of the bars), rub the commutator with a pencil eraser. If the marks are erased the bar is only flecked and it may be assumed that the sparking is not destructive.

(2) **Cleaning Commutator:** If small pits or streaks still remain on the leaving edges of the bars, the sparking is probably caused by destructive copper etching. In this case, remove the brushes and clean the commutator with a KS-2423 cloth dampened with KS-19578, List 1 trichloroethane, turning the shaft by hand.

(3) **Resurfacing Commutator:** If sparking is still excessive after the commutator has been cleaned, remove the armature. With a piece of 400A Aloxite paper wrapped lightly around the commutator, the armature shall be rotated in one direction only. No attempt shall be made to remove grooves or pits. If the commutator is pitted or grooved in excess of 0.010 inch, it should be sent to a repair shop equipped to turn down the commutator on a lathe. Clean out all particles that remain in the gaps between the commutator segments.

(f) **Motor Bearings:** Examine the motor bearings. If necessary, clean and repack the bearings in accordance with the instructions outlined in the section covering the general requirements for the lubrication of teletypewriter apparatus.

(g) **Reassemble the motor.** Avoid touching the commutator with the hands or fingers as grease and perspiration may cause burned spots or poor contacts.

#### 2.04 Governors:

(a) **Governor Contacts:** These requirements are common to single-speed and two-speed governors. They need not be checked unless there is evidence that the contacts are causing trouble or unless the governor is disassembled for other reasons.

(1) **Contact Surface:** A uniform surface over the greater portion of the contact face is a desirable condition. Where the

contact surfaces are deeply pitted or have buildups, no attempt shall be made to remove pits or buildups, but the contacts shall be replaced. See Figures 5, 7, and 16(A).

(2) **Contact-spring Block:** With the speed-adjusting spring removed, there shall be at least 0.010-inch clearance between the contact-spring block clamp and the inner rim of the governor shell. Gauge by eye.

**To Adjust:** Position the contact-spring block by means of its mounting screws. On governors having peripheral or edge-contacting slip rings, note that this gap is free of dirt and metal particles which may tend to short-circuit the rings and the governor contacts. See Figures 7 and 16(B).

(3) **Governor Contact Clearance:** With the speed-adjusting (retractile) spring removed, there shall be a gap of minimum 0.015 inch, maximum 0.040 inch between the governor contacts.

**To Adjust:** Bend the governor contact spring. See Figures 5, 7, and 16(A).

(4) **Governor Contact Alignment:** With the speed-adjusting (retractile) spring in place, governor contacts shall be in line and meet squarely so that the maximum contact surface is provided. Gauge by using a 0.002-inch gauge (or smaller, if available) on all sides of the contacts. If the contacts are adjusted correctly, the gauge shall not enter between the contacts on any side.

**To Adjust:** Adjust the speed-adjusting spring until the contacts just make, or to the minimum tension allowed by the adjusting wheel and its screw. Line up the edges of the contacts by loosening the screw in the contact-spring clamp and reposition the contact spring so that the edge of its contact coincides with the edge of the fixed contact. In order to align the contacts so that their faces are parallel from front to back, twist the contact-spring hinge with a pair of long-nose pliers by applying pressure to the contact spring near the contact. In order to align the contacts so that their faces are parallel side to side, one of the two options given as follows shall be used.

**Option 1:** Where the governor shell is provided with elongated holes for the fixed-

contact-block mounting screws, loosen the screws and move the block up or down as shown in Figure 5 until the contact faces are parallel. Tighten the mounting screws.

**Option 2:** Where the governor shell does not have elongated holes for the fixed-contact-block mounting screws, loosen the screws and move the block from side to side as shown in Figure 5 until the contact faces are parallel. Tighten the mounting screws. If the contact faces cannot be made parallel by either of the two options given above, remove the contact spring and check with the TP95960 tape gauge used as a straightedge as shown in Figure 6. When necessary, bend the contact spring at the first bend from the contact. (See Figures 5, 6, 7, and 16.)

(b) **Adjusting-wheel Friction Washer (Single-speed Governor):** It shall require minimum 16 ounces, maximum 24 ounces to start the adjusting wheel moving.

**To Gauge:** Rotate the adjusting wheel to a point where the governor-contact pressure is minimum 13 ounces, maximum 14 ounces

when the pull end of the 32-ounce scale is hooked over the contact spring at the contact and pulled parallel to the speed-adjusting spring and the contacts just opened. Insert a common pin radially into the leather rim of the adjusting wheel and hook the pull-end of the 32-ounce scale over the pin at the leather and pull at a tangent to the circumference of the adjusting wheel.

**To Adjust:** Remove the friction washer and bend the large projections. (See Figure 7.)

(c) **Speed-adjusting-lever Stop Plate:** On all governed motors equipped with speed-adjusting lever TP7661, there shall be from minimum 0.006-inch, maximum 0.050-inch clearance between the adjusting lever wearing strip and the governor, when the speed-adjusting lever is held against the stop plate.

**To Adjust:** Position the adjusting lever stop plate by means of its elongated mounting holes. (See Figure 9.)

**CAUTION** DO NOT ATTEMPT TO CHECK THE ABOVE REQUIREMENT OR MAKE THE ABOVE ADJUSTMENT WITH THE MOTOR RUNNING.

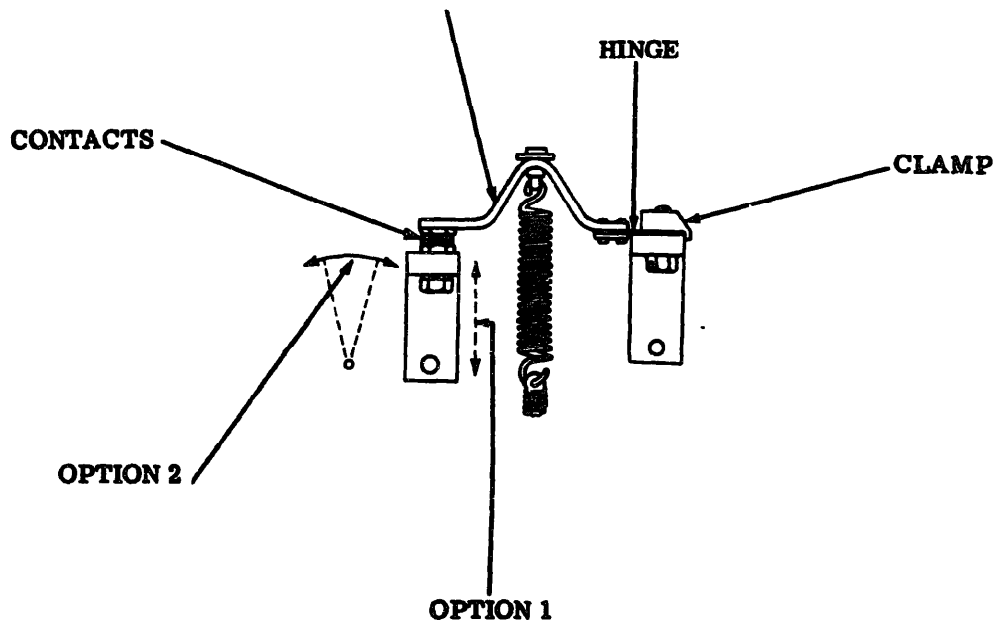

Figure 5- Governor Contacts

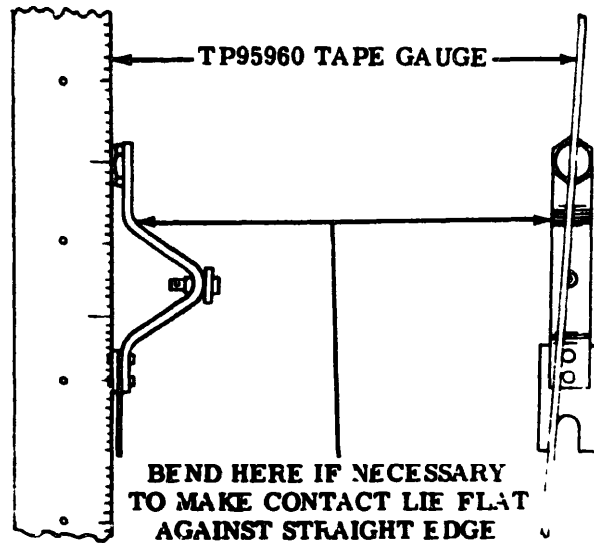

Figure 6- Tale Gauge

**(d) Center-contacting-type Governors**

**(1) Contact Springs:** The distance from the inner surface of the governor cover to the highest point on the contact springs shall be minimum  $25/32$  inch, maximum  $27/32$  inch.

**To Adjust:** Bend the springs. (See Figure 8.)

**(2) Inner-disc Contact Spring:** With the TP135678 socket wrench placed over the nut which holds the contact springs in place, the distance from the outer surface of the wrench to a point where the TP95960 tape gauge, used as a ruler, touches the curved surface of the inner-disc contact spring shall be minimum  $17/32$  inch, maximum  $19/32$  inch.

**To Gauge:** Place the end of the TP95960 tape gauge against the outer surface of the wrench so that the edge of the  $1/32$ -inch

scale is resting against the curved surface of the inner-disc contact spring.

**To Adjust:** Bend the spring. Recheck (1). (See Figure 8.)

**(3) Outer-disc Contact Spring:** With the socket wrench in position as in (2), the distance from the outer surface of the wrench to a point where the tape gauge touches the curved surface of the outer-disc contact spring shall be minimum  $7/16$  inch, maximum  $1/2$  inch. To gauge, place the end of the TP95960 tape gauge against the outer surface of the wrench so that the edge of the  $1/32$ -inch scale is resting against the curved surface of the outer-disc contact spring.

**To Adjust:** Bend the spring. Recheck (1). (See Figure 8.)

**(4) Governor-brush-spring-plate Bracket:** The inner surface of the bracket shall

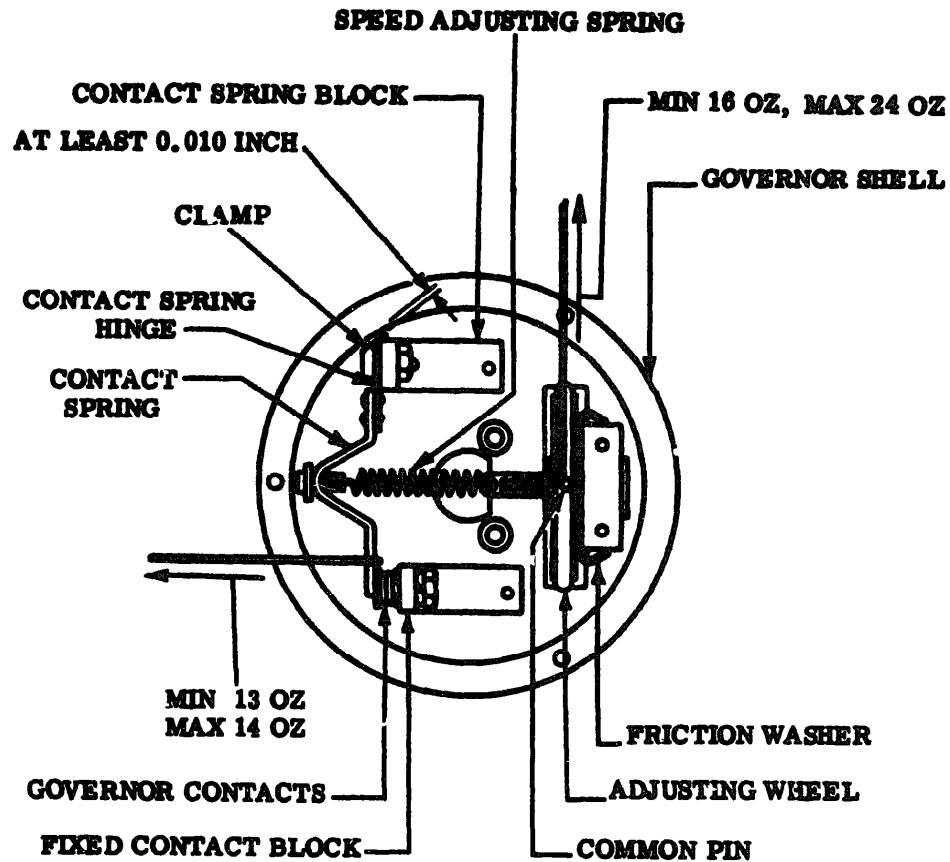

Figure 7 - Center Contact Governor Assembly.

be parallel to the governor cover. Gauge by eye.

**To Adjust:** Loosen the brush-spring-plate mounting screws and reposition the bracket. Tighten the screws. (See Figure 9.)

(5) **Contact Discs:** A smooth, even, bronze-colored glaze is a desirable condition for the contact surfaces of the discs and they shall not be disturbed unless there is excessive sparking under the

brushes. Gauge by eye. When it is necessary to clean the discs, a KS-2423 cloth, wrapped around an orange stick and moistened with KS-19578, List 1 trichloroethane, shall be held on each disc while the motor is being rotated by hand and the brushes have been removed. If the discs are pitted or burned, a piece of 400A Alomite wrapped around an orange stick shall be held against each disc while the motor is being rotated by hand. Badly grooved discs shall be replaced. (See Figure 8.)

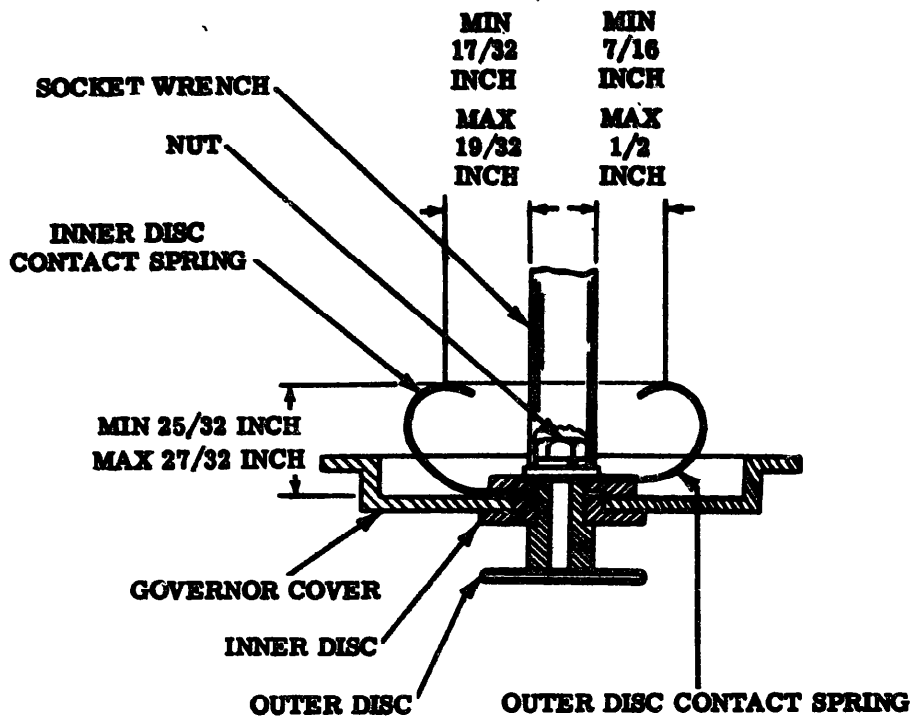

Figure 8- Governor Cover Contact Spring Disk Assembly

(6) Governor brushes shall lie flat against their discs and there shall be minimum  $3/32$  inch of the brush material remaining. Gauge by eye.

**To Adjust:** Level off the brush by passing a piece of 400A Aloxite between the brush and the disc. If there is less than  $3/32$  inch of the brush remaining, replace the brush. (See Figure 10.)

(7) Inner-disc Brush-spring Tension: It shall require minimum  $4\text{-}1/2$  ounces, maximum  $5\text{-}1/2$  ounces to start the brush moving away from its disc.

**To gauge:** Hook the pull end of the 8-ounce scale over the brush spring at the brush and pull horizontally away from the motor.

**To Adjust:** Remove and bend the brush spring. Reassemble the spring and recheck (6). (See Figure 9.)

(8) Outer-disc Brush-spring Tension: It shall require minimum  $4\text{-}1/2$  ounces, maximum  $5\text{-}1/2$  ounces to start the brush moving away from its disc.

**To Gauge:** Apply the push end of the 8-ounce scale to the brush spring at the brush and push horizontally toward the motor.

**To Adjust:** Remove and bend the brush spring. Reassemble the spring and recheck (6). (See Figure 9.)

(9) Governor-brush Alignment: The outer edge of the brushes shall be within  $3/64$  inch of the outer edge of the discs throughout one revolution of the governor; and a line established by the center of the outer disc and the center of one of the brushes shall pass through some portion of the other brush.

**To Gauge:** Remove the governor-adjusting bracket.

**To Adjust:** Reposition the brush spring by means of its mounting slot. Reassemble the governor-adjusting bracket. (See Figure 11.)

(10) Governor-adjusting Bracket: There shall be a clearance of minimum 0.020 inch, maximum 0.060 inch between the



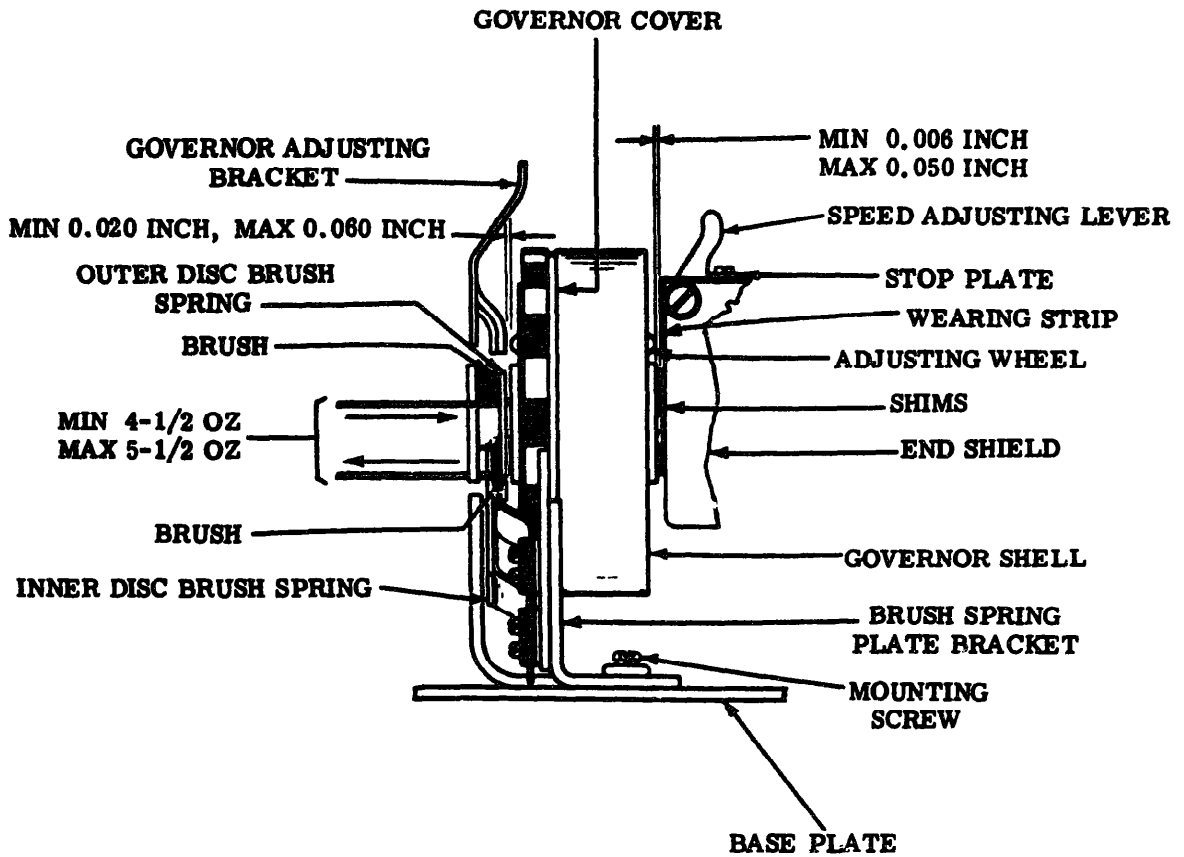

Figure 9- Governor Brush Spring Plate Bracket Assembly

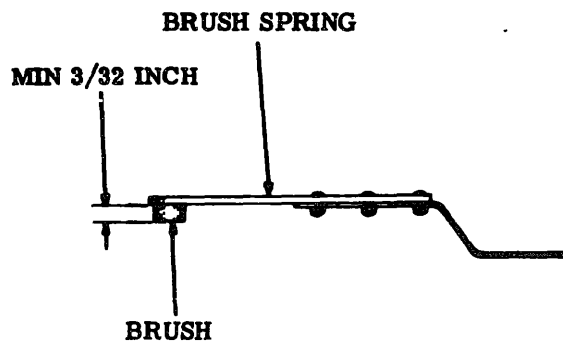

Figure 10- Brush Spring Assembly

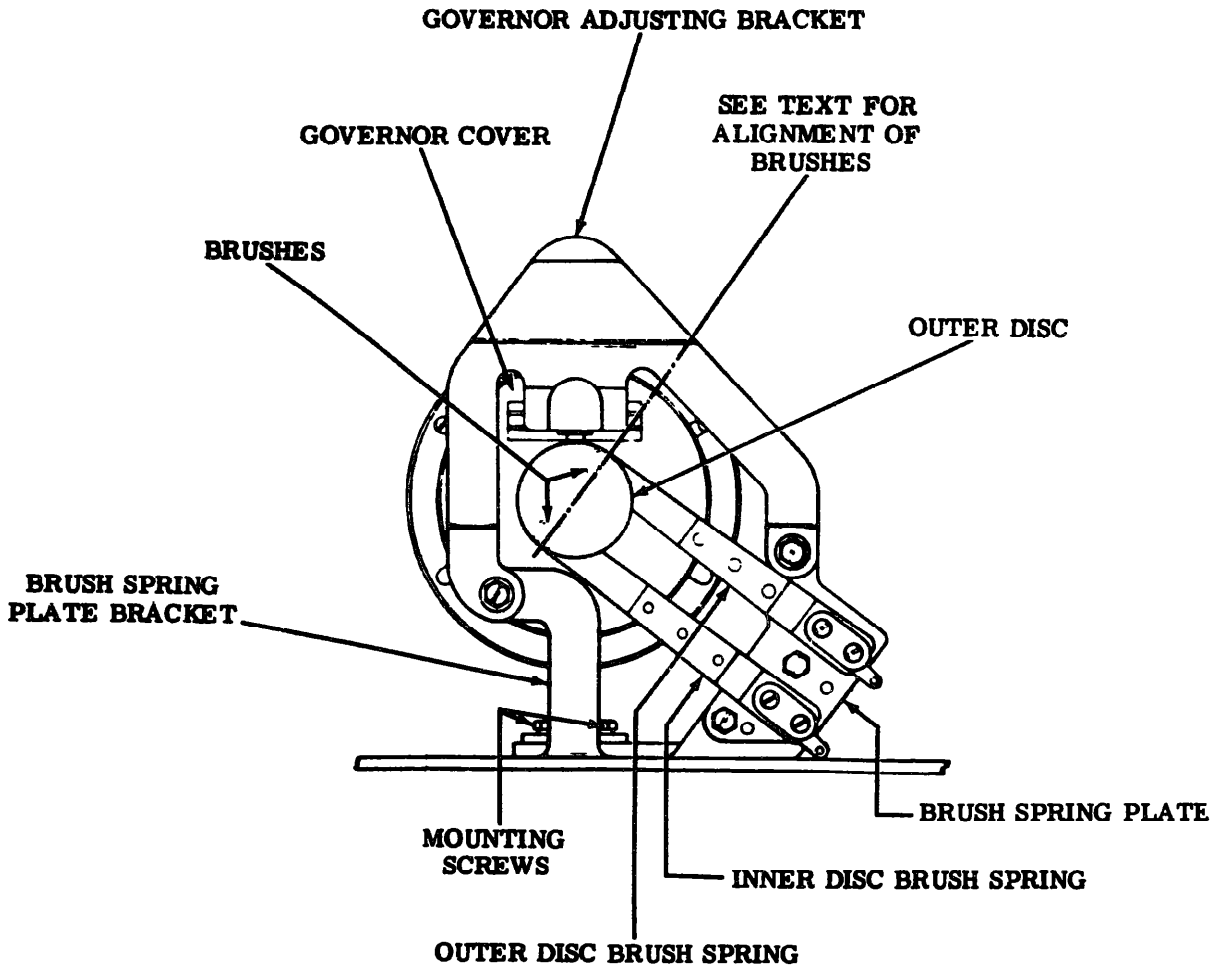

Figure 11- Governor Adjusting Bracket Assembly

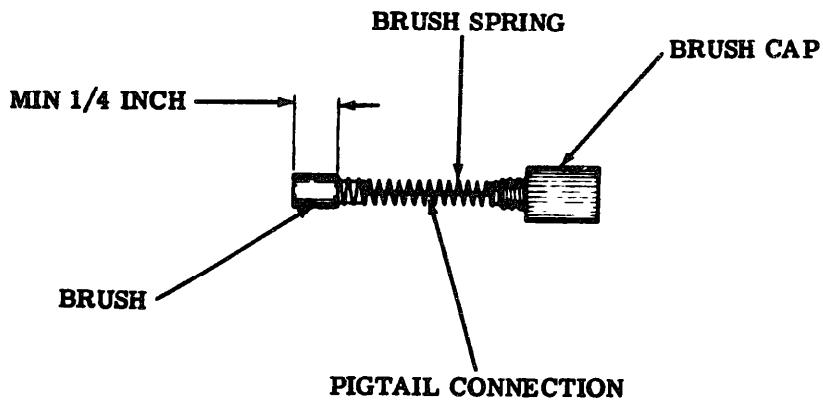

Figure 12- Governor Brush

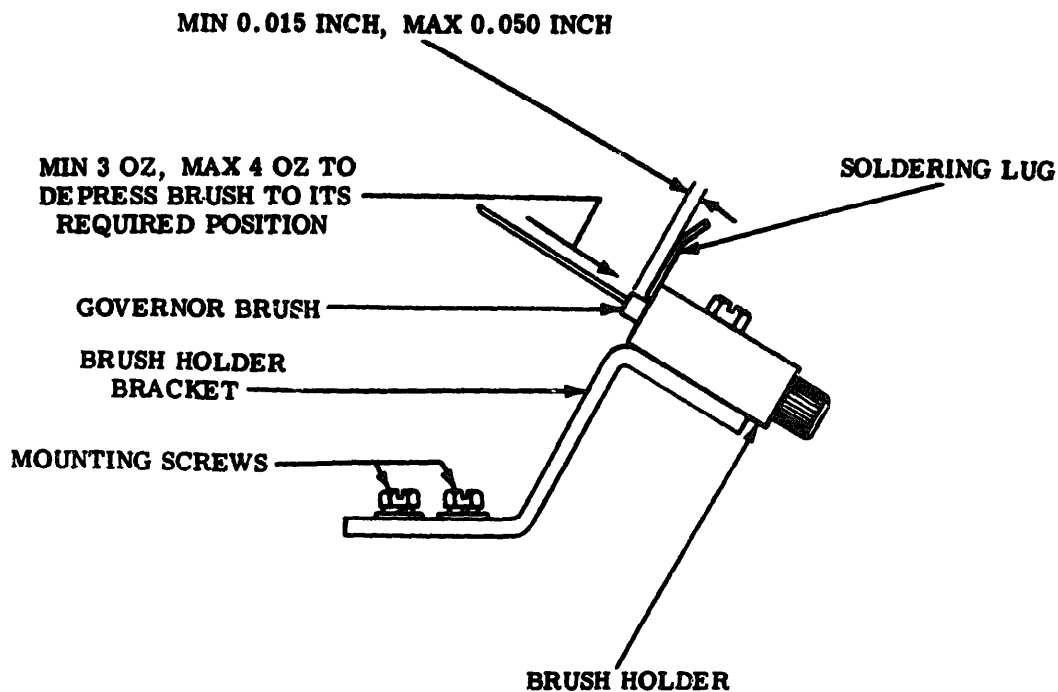

Figure 13- Governor Brush Bracket Assembly

adjusting wheel and the governor-adjusting bracket. This requirement shall be ignored if the bulge near the center of the adjusting bracket is omitted in manufacture.

**To Gauge:** Rotate the governor until the adjusting wheel is opposite the adjusting surface of the governor-adjusting bracket.

**To Adjust:** Bend the governor-adjusting bracket. (See Figure 9.)

(e) **Edge-contacting-type Governors:** The following brush requirements are also applicable to the TP138598 auxiliary brush holder assembly (specification 3125S and 5332S).

(1) **Governor Brushes:** There shall be minimum 1/4 inch of the brush material remaining on each brush, the braided wire pigtail connection inside the brush spring shall be free from kinks which may prevent the spring from extending properly, and the wire shall be securely fastened to the brush and the brass insert of the brush cap. Gauge by eye. If the brush has less

than 1/4 inch of its material remaining or if the spring is mutilated, replace the brush. (See Figure 12.)

(2) **Alignment of Governor Brushes:** The governor brushes shall ride approximately in the center of the governor rings. Check for a full revolution.

**To Adjust:** Reposition bracket by means of its mounting screws. (See Figure 14.)

(3) **Governor-brush Spring Tension:** It shall require minimum 3 ounces, maximum 4 ounces to hold the brush in its normal position (within minimum 0.015 inch, maximum 0.050 inch of the brush holder).

**To Gauge:** Remove the brush holder from the brush holder bracket, remove the brushes from the holder, and clean each brush with a KS-2423 cloth moistened with KS-19578, List 1 trichloroethane. Clean out the holes in the holder into which the brushes are pushed and reinsert the brushes, making sure that the brushes move freely in the holder. Using the push end of the 8-ounce

scale, depress that portion of the brush which extends beyond the holder until the end of the brush is within minimum 0.015 inch, maximum 0.050 inch of the holder. Where springs do not meet the requirement, replace the governor-brush-spring assembly. Reassemble the brush holder. (See Figure 13.)

(4) **Brush Holder:** There shall be minimum 0.015-inch, maximum 0.050-inch clearance between the brush holder and the rings through one complete revolution of the governor.

**To Adjust:** Loosen the brush-holder mounting screws and reposition the brush holder. Tighten the mounting screws. (See Figure 14.)

(5) **Two-speed Governor-adjusting-wheel Detent-spring Pressure:** The detent spring shall rest on the adjusting wheel; (1) in all positions of the adjusting wheel,

(2) at the point of minimum pressure with a minimum 2-ounce, maximum 4-ounce pressure.

**To Gauge the Pressure:** With the detent spring resting between the notches on the adjusting wheel, hook the 8-ounce scale to the spring near the adjusting wheel as shown by (A) in Figure 15. With the scale in a horizontal position, pull at right angles to the spring. To determine the minimum pressure point, the check shall be made at three points approximately equally spaced around the periphery with the wheel in its final revolution at each end of its travel.

**To Adjust:** Loosen the clamping screw and lock-nut and shift the detent spring as required. Moving the spring higher up on the rim of the wheel increases the tension and shifting the spring lower on the wheel decreases the tension. If satisfactory pressure cannot be obtained in this way, remove the clamping screw and locknut and bend

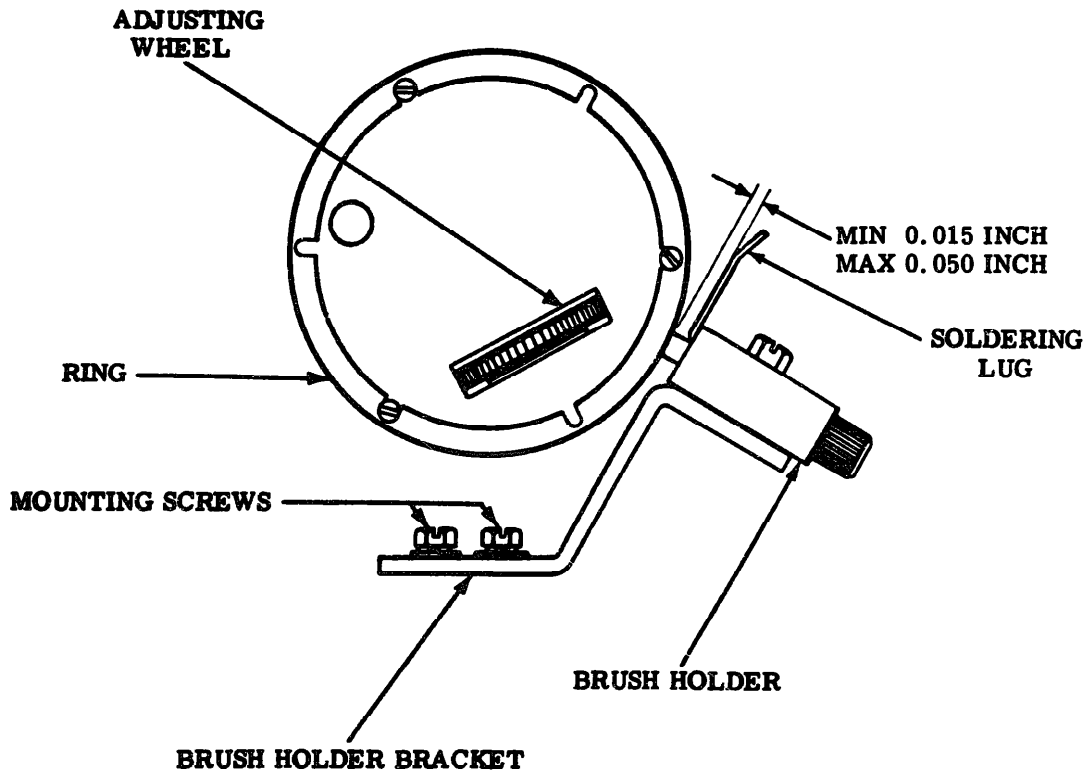

Figure 14- Governor Adjusting Wheel

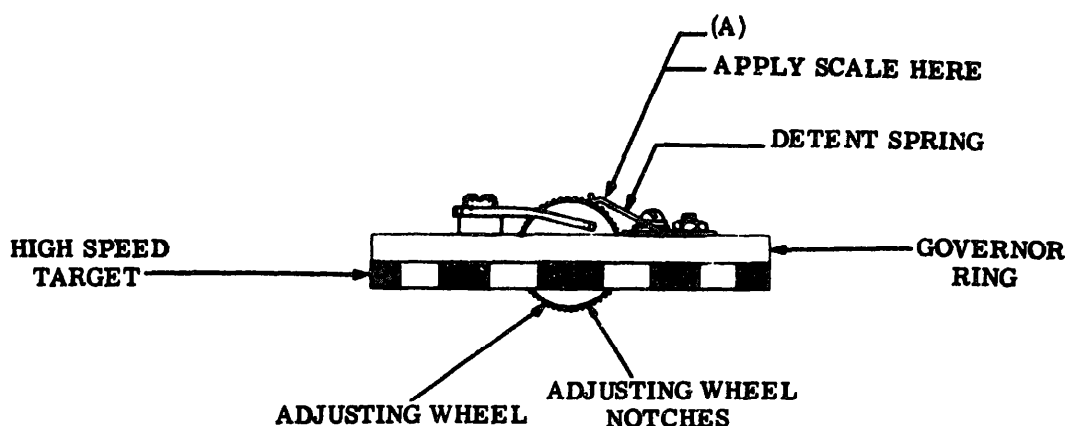

Figure 15 - Half of Two-speed, Edge-contacting Governor

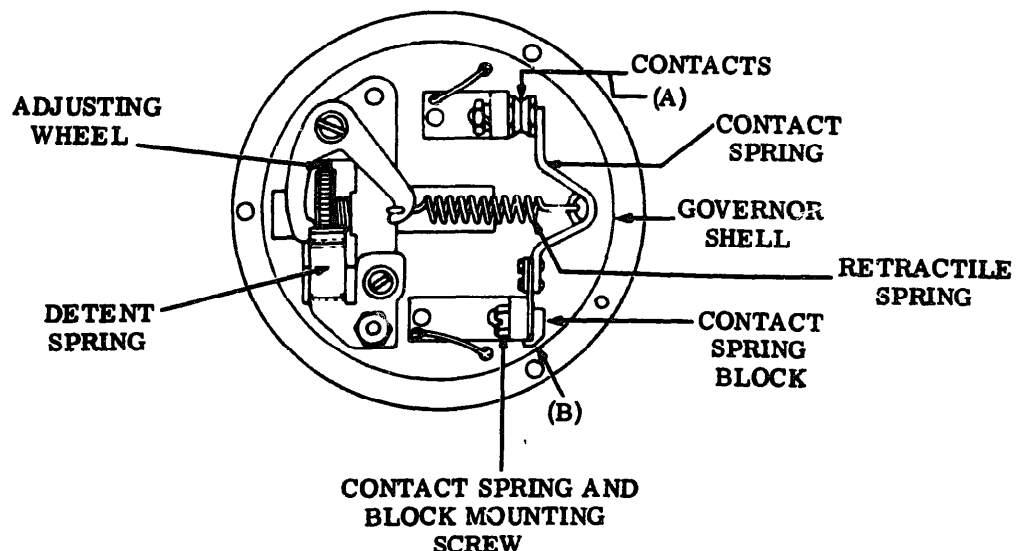

Figure 16- Two-Speed Edge-Contacting Governor-Interior View of Half of Governor

the detent spring as required. Position the spring on the wheel and tighten the screw and nut. (See Figure 15.)

(6) **Governor Rings:** A smooth, even, bronze-colored glaze is a desirable condition for the contact surface of the rings and they shall not be disturbed unless there is excessive sparking under the brushes. Gauge by eye. When it is necessary to clean the rings, a KS-2423 cloth moistened with KS-19578, List 1 trichloroethane shall be

held against the rings while the motor is in motion. To remove burned spots from the rings, a piece of 400A Aloxite held lightly against the rings while the motor is in motion, along with a KS-2423 cloth to immediately wipe off the cuttings and sand, may be used. (See Figure 15.)

(7) **Governor-brush contact surface** shall be curved to fit the contour of the rings. Gauge by eye. To resurface the brushes, hold a piece of 400A Aloxite around the

outer shell of the governor between the brushes and the shell and rotate the governor back and forth by hand. The last rotation shall be in the normal direction of travel. (See Figure 14.)

(8) Adjusting Governor Speed: With the motor at rest, turn the adjusting wheel (Figure 7 or 16) as indicated by the letters S and F to decrease or increase the speed respectively. On two-speed governors, the

outer adjusting wheel is for adjusting the high speed, and the inner adjusting wheel is for adjusting the low speed. As the inner adjusting wheel is not very accessible, a screwdriver or other slender object should be used to engage it. Tuning fork TP103628 (87.5 V.P.S.) is recommended for setting the speeds, as explained in the section covering the speed regulation of teletypewriter apparatus. (See Figures 7 and 16.)

3. REQUIREMENTS AND ADJUSTMENTS- 28, 35, AND 37 TYPE MOTOR UNITS  
3.01 Miniaturized Synchronous Motor Units

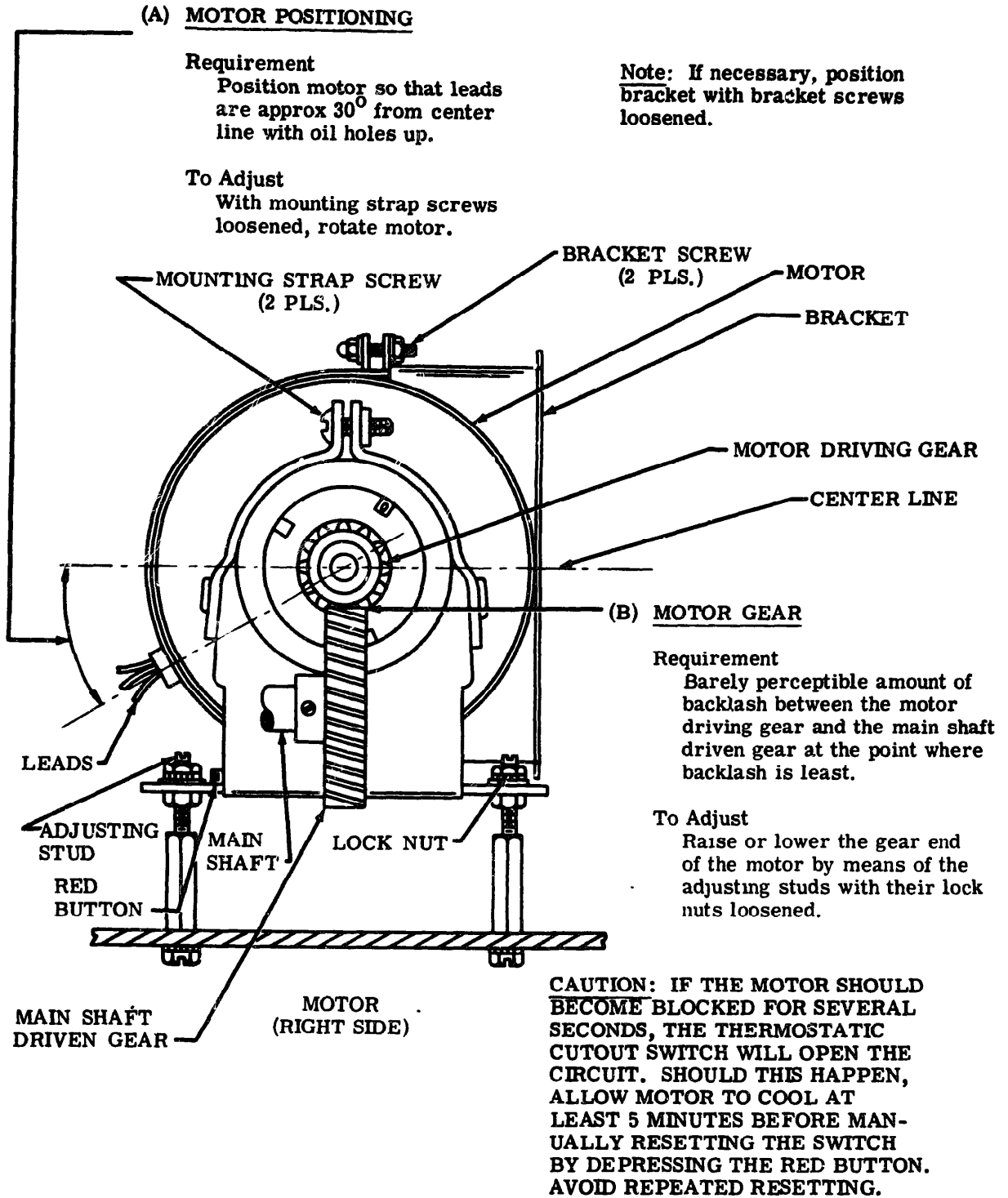

3.02 Miniaturized Synchronous Motor Units (continued)

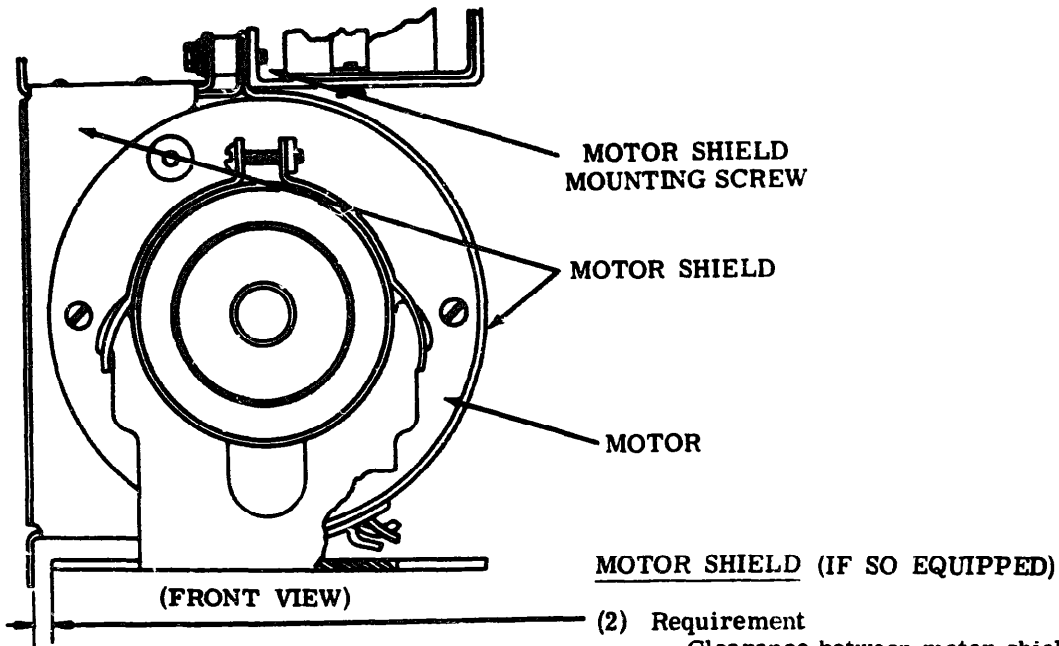

- (2) Requirement  
Clearance between motor shield and motor mounting bracket should be  
Min 0.062 inch
- To Adjust  
Position motor shield with its mounting screws loosened.

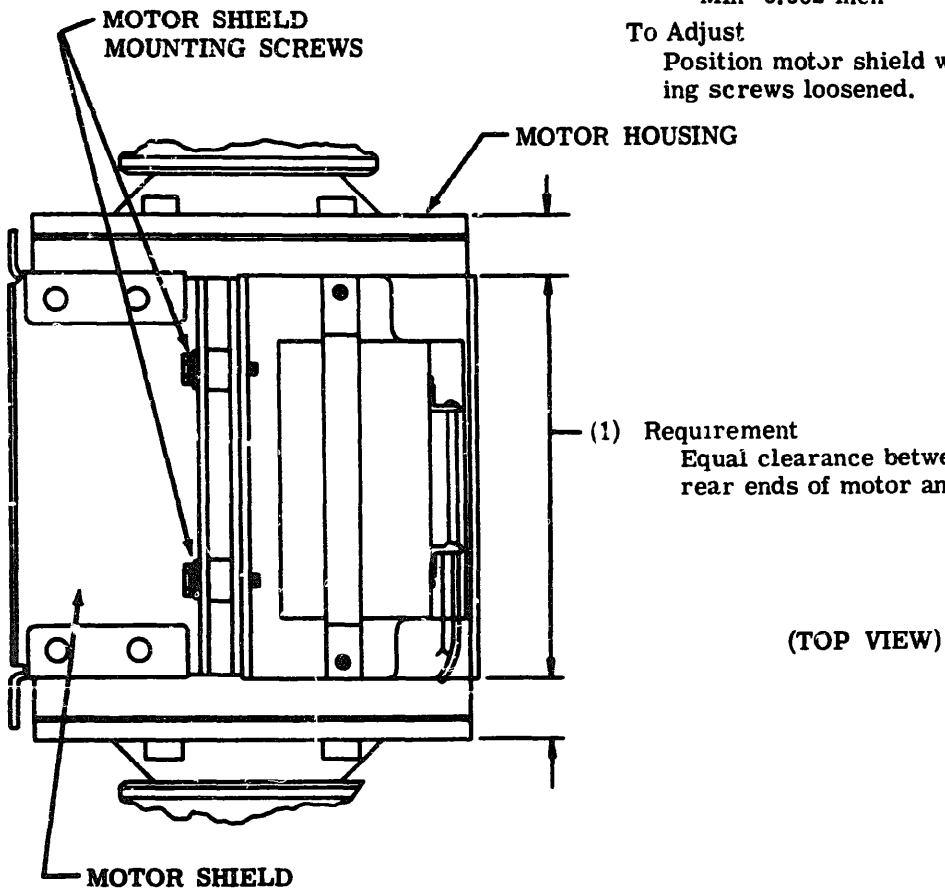



3 . 0 3 **Miniaturized Synchronous Motor Units (continued)**

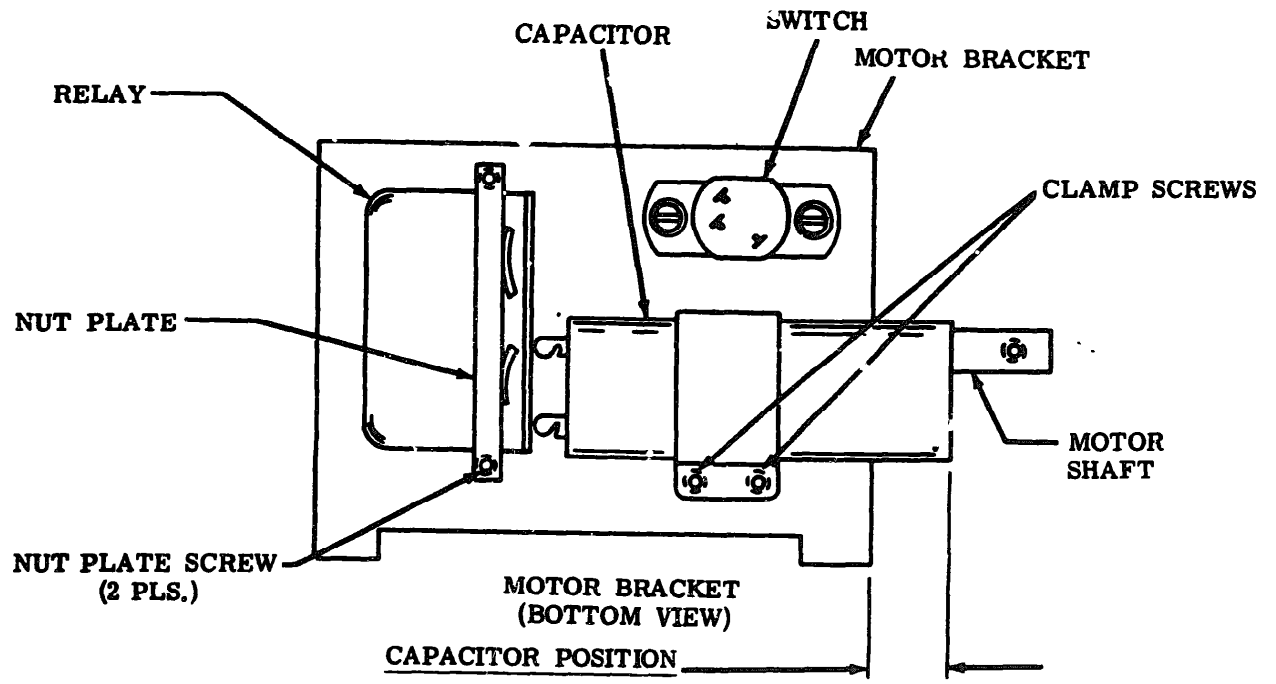
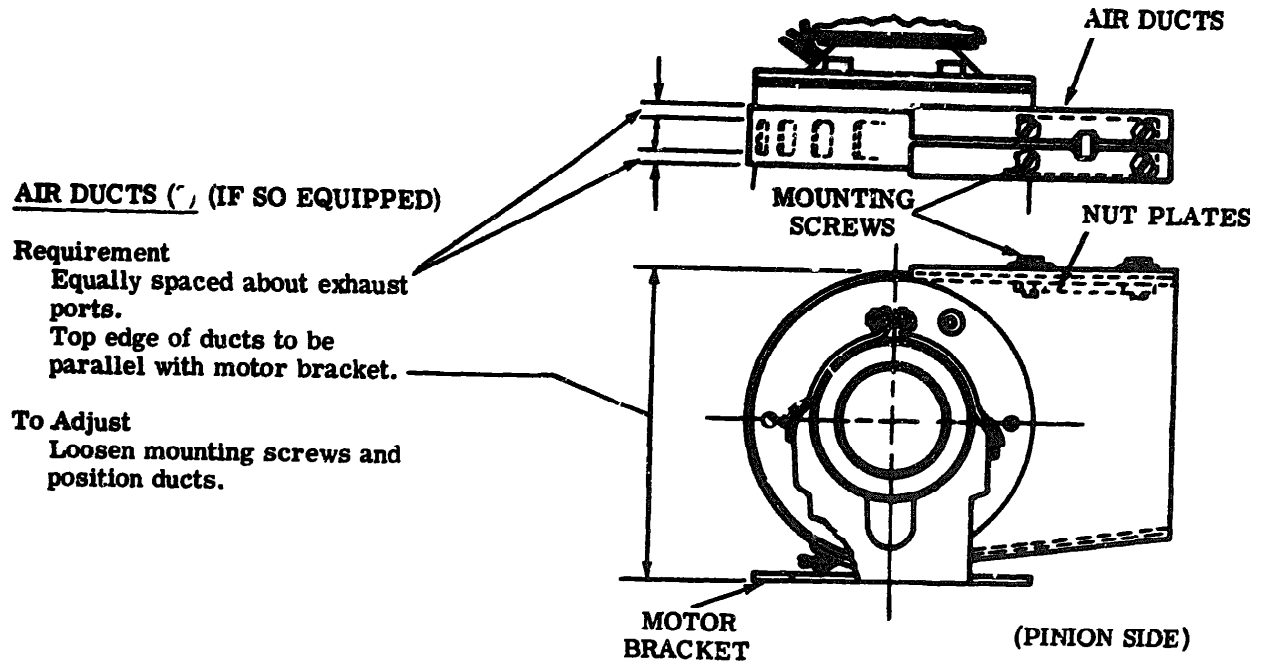

**Requirement**  
 Max 1/2 inch between motor bracket and end of capacitor.

**To Adjust**  
 Position relay and capacitor with motor removed from motor bracket and nut plate and clamp screws loosened.

3.04 Standard and Heavy Duty Synchronous Motor Units

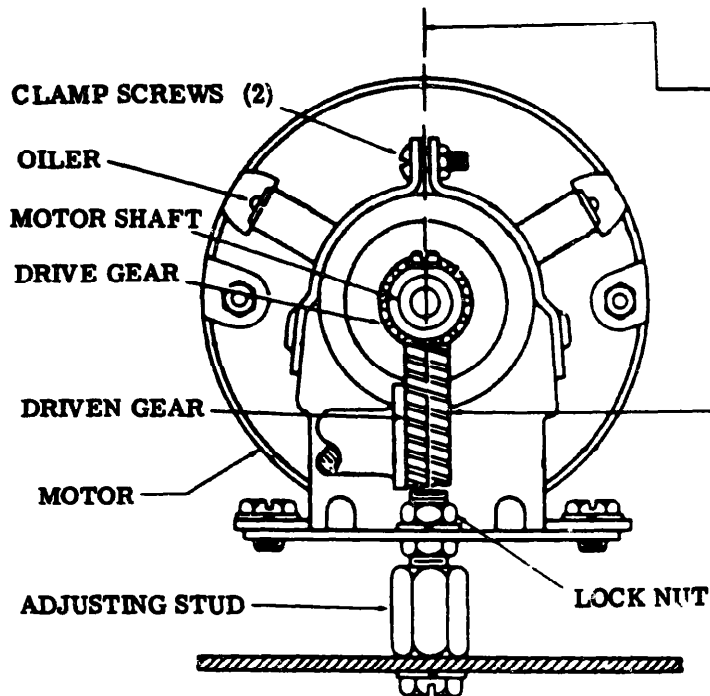

**MOTOR POSITIONING**

- (1) Requirement (Upright Mounted Motors)  
Oilers should be upward and approximately equidistant from a vertical line through motor shaft.
- (2) Requirement (Inverted Mounted Motors)  
Oilers should be downward and approximately equidistant from a vertical line through motor shaft.

To Adjust  
Position motor with clamp screws (2) loosened.

**MOTOR ADJUSTING STUD (IF SO EQUIPPED)**

Requirement  
Barely perceptible backlash between drive gear and driven gear at point where backlash is least.

To Adjust  
With lock nut loosened, position adjusting stud. Tighten nut while holding stud in position.

**CAUTION: IF MOTOR BECOMES BLOCKED FOR SEVERAL SECONDS, THERMOSTATIC CUTOFF SWITCH (ON UNITS SO EQUIPPED) WILL BREAK CIRCUIT. SHOULD THIS HAPPEN, ALLOW MOTOR TO COOL AT LEAST 5 MINUTES BEFORE DEPRESSING RED RESET BUTTON. AVOID REPEATED RESETTING.**

3.05 Standard and Heavy Duty Synchronous Motor Units (continued)

**CENTRIFUGAL SWITCH**

**(1) Requirement**

With motor stopped (centrifugal switch extends toward contacts) and contact assembly closed there should be  
Min 0.020 inch  
of overtravel as gauged by eye.

**To Adjust**  
With contact assembly screws friction tight, adjust contact assembly to meet requirements. Tighten screws.

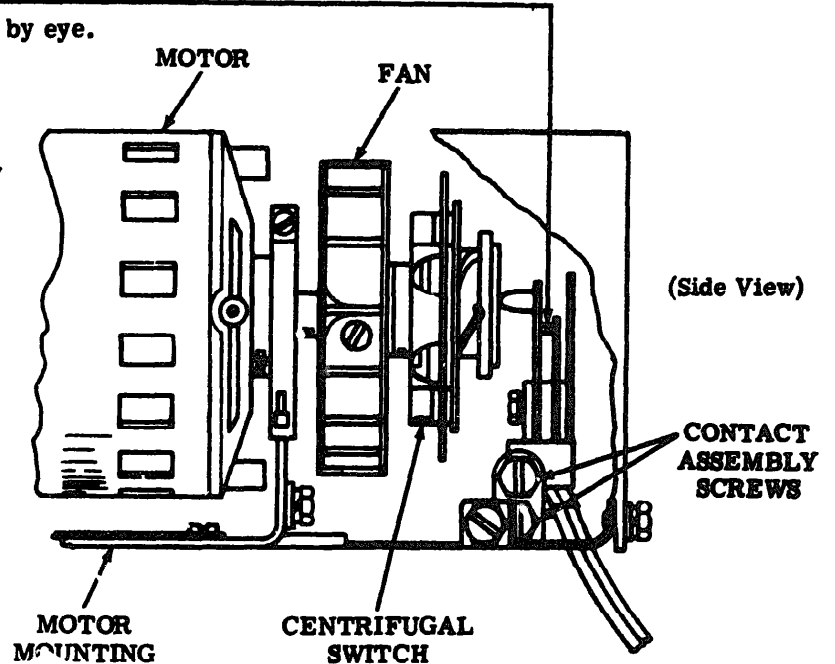

**(2) Requirement**

With motor running (centrifugal switch toward motor) there should be  
Min 0.015 inch---Max 0.025 inch  
clearance between contacts.

**To Adjust**  
With motor stopped and contact assembly screws friction tight, adjust contact assembly to meet requirement (1). Tighten screws. If requirement (2) is not met, refine requirement (1).

**(3) Requirement**

Clearance between centrifugal switch assembly and metal cover should be  
Min 0.050 inch.

**To Adjust**  
With mounting cover screws friction tight, lower cover until interference is felt; then raise cover to meet requirement. Tighten screws.

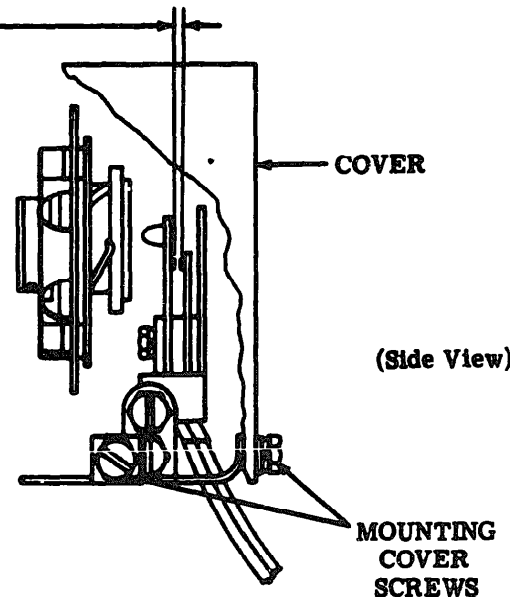

3 . 0 6 Series Governed Motor Units

**MOTOR POSITIONING (NOT ILLUSTRATED)**

**Requirement**

Motor should be centrally positioned in its rubber mounts so as to provide at least 0.020 clearance between the motor housing and the cradle at the governor end. The cable should also clear the grommet in the screen by at least 0.030 inch.

**(A) GOVERNOR CONTACT BACKSTOP**

**Requirement**

Clearance between the movable contact arm and its eccentric backstop.

Min 0.020 inch---Max 0.040 inch

**To Adjust**

Rotate the eccentric backstop with clamping screw loosened.

**(B) GOVERNOR CONTACT**

**Requirement**

The contacts should meet squarely and not overlap more than 0.010 inch.

**To Adjust**

Position the stationary contact and contact arm with the clamp screw and post loosened.

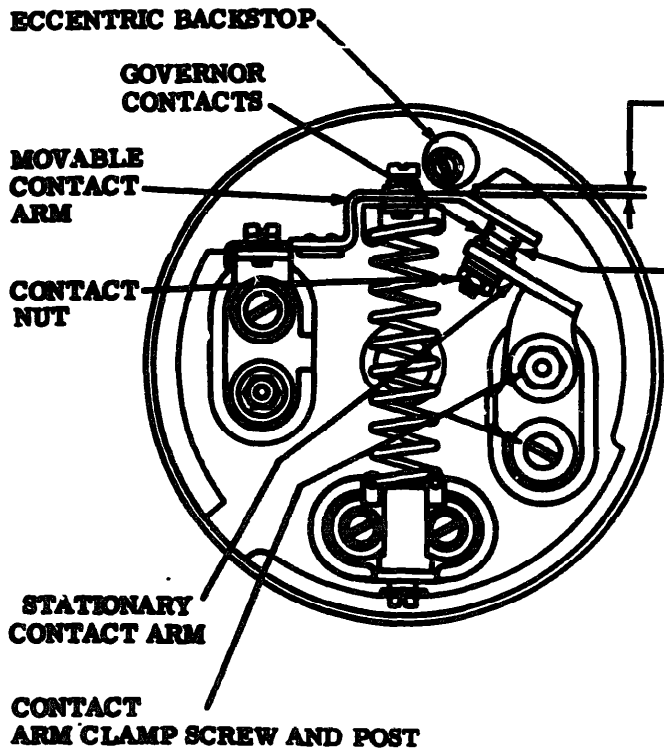

**CAUTION: EXCESSIVE PRESSURE AGAINST GOVERNOR COVER ASSEMBLY DURING REMOVAL MAY DAMAGE SCREENED WINDOW.**

3.07 Series Governed Motor Units (continued)

**Note:** Replace governor brushes that have worn to a length of approximately 15/32 inch (2/3 of original length).

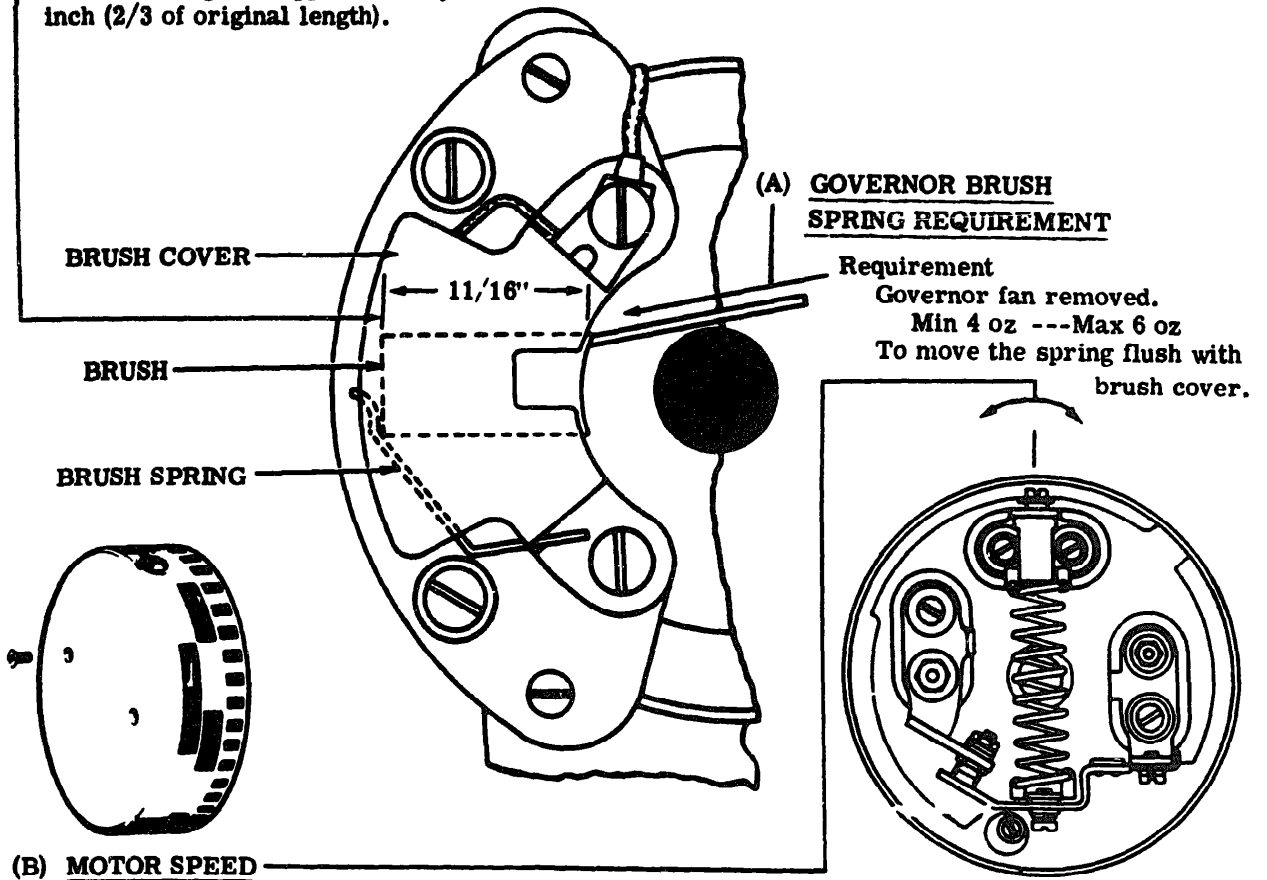

**Requirement**

With target illuminated and viewed through the vibrating shutters of a 120 vps turning fork the spots on the 4-spot target should appear stationary while rotating. With target illuminated and viewed through the vibrating shutters of an 87.6 vps tuning fork the spots on the 6-spot target should appear stationary while rotating and with speed slightly increased the spots on the 35 spot target should appear stationary.

**To Adjust**

Stop the motor and turn the adjusting screw as indicated on governor cover. For units with screened governor covers, stop the motor, remove the TP152035 plug from cover. Turn adjusting screw as indicated on periphery of target.

**Note:** It is possible to adjust the motor at some multiple of the correct speed. To check motor speed when used with a page printer, return typebox carriage to left margin, set up any character in selector and manually trip typebox clutch trip lever. Printing should occur as follows:

WPM	PRINTED CHARACTERS	REQUIRED TIME
60	70	10 seconds
75	44	5 seconds
100	57	5 seconds

3.08 Series Governed Variable Speed Motor Units

**BRAKE SHOE SLIDE**

**(1) Requirement**

Clearance between engaging surface of respective disc and associated shoe should be  
Min 3/32 inch---Max 1/8 inch

**To Adjust**

With bearing plate mounting screws friction tight, position the plate toward front or rear to centrally locate shoe assembly.

**(2) Requirement**

With front and rear brake guide mounting screws friction tight, position guides toward right or left to obtain alignment between governor shoes and corresponding discs

**To Adjust**

Maintain some clearance between governor gears and closest shoe when play of brake slide is taken up to make the clearance a minimum. Tighten screws.

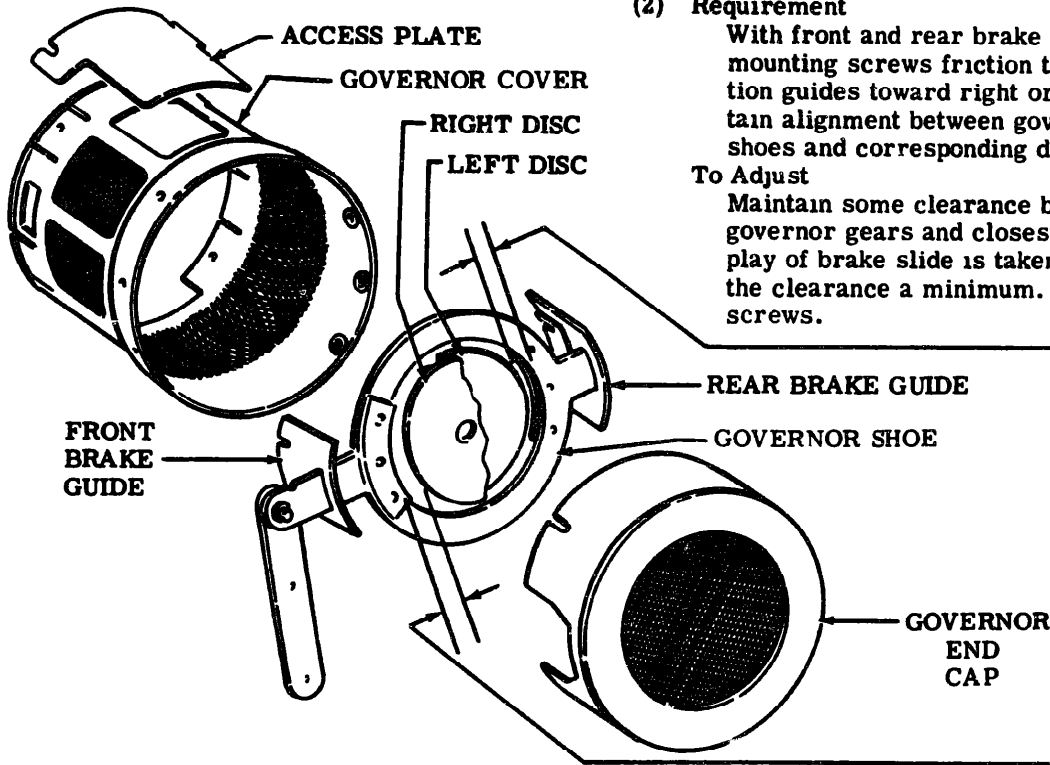

**SPEED CONTROL LINKAGE BEARING PLATE (PART OF BASE)**

**Requirement**

Plane of speed control lever should be parallel with brake slide lever assembly and function without binds.

**To Adjust**

With control lever bearing plate mounting screws loosened, add or remove shims to align levers.

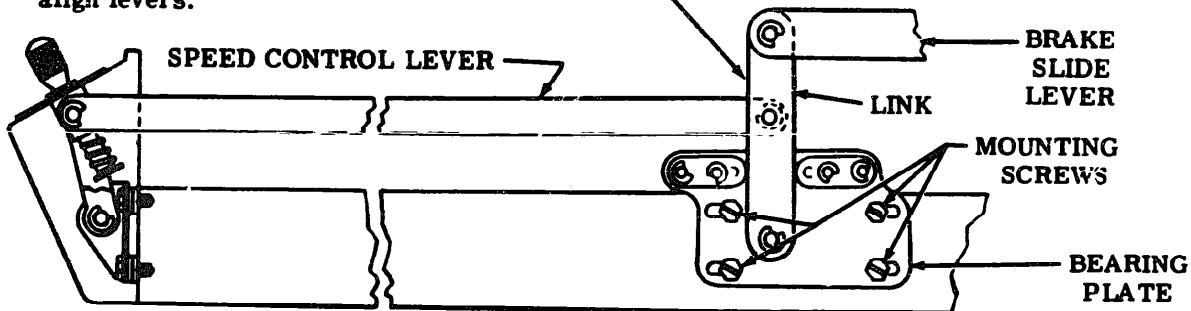
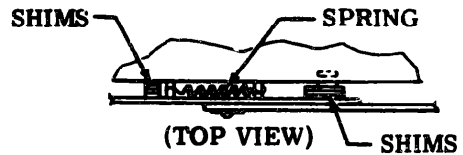

3 . 0 9 Series Governed Variable Speed Motor Units (continued)

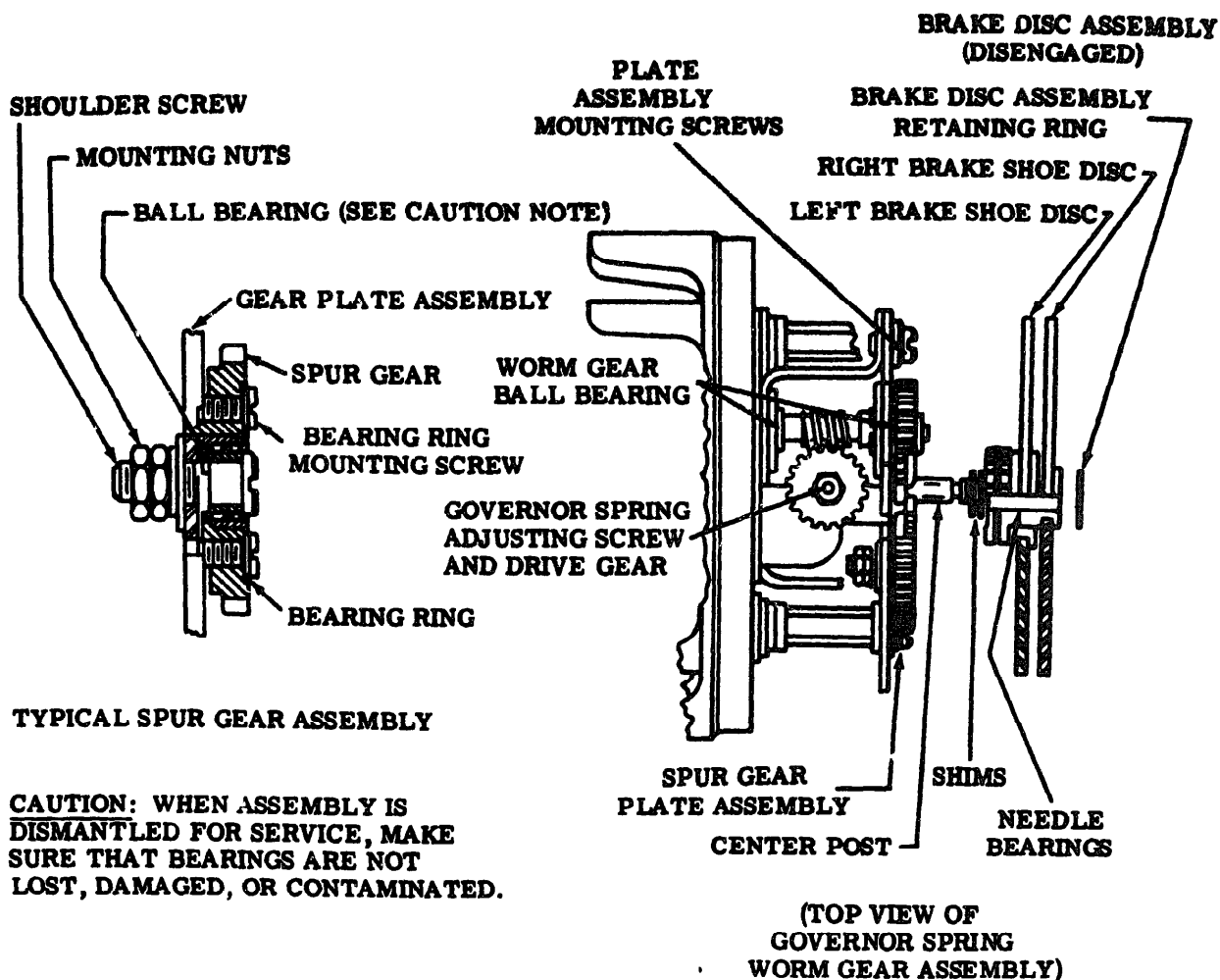

**CAUTION: WHEN ASSEMBLY IS DISMANTLED FOR SERVICE, MAKE SURE THAT BEARINGS ARE NOT LOST, DAMAGED, OR CONTAMINATED.**

**GOVERNOR SPUR GEAR TRAIN**

**(1) Requirement**

Backlash between the six mating spur gears should be barely perceptible. Do not mistake side play of gear mounting for backlash.

**Preliminary Procedure**

Remove brake disc assembly with its retaining ring removed from center post of gear plate. Remove spur gear plate assembly hardware from the four posts and remove the assembly. Note the location of fibre washers, etc. Remove bearing screw locknuts from spur gears B and C; then remove each gear, post, and bearing intact (see 3.10).

**CAUTION: MAKE SURE BALL BEARINGS ARE NOT DAMAGED, LOST, OR CONTAMINATED.**

Loosen locknuts on spur gear D.

**To Adjust**

Position bearing screw of spur gear on gear plate to provide perceptible backlash for spur gears A and D.

**(2) Requirement**

With brake disc assembly replaced in the spur gear plate assembly, backlash between spur gear D and mating gear in brake disc assembly should be barely perceptible.

**To Adjust**

Refine position of spur gear D mounting screw (Requirement (1) above).

## 3.10 Series Governed Variable Speed Motor Units (continued)

**GOVERNOR SPUR GEAR TRAIN (continued)****(3) Requirement**

With brake disc assembly removed and spur gear B replaced in gear plate assembly, backlash between spur gear A and spur gear B should be barely perceptible.

**To Adjust**

Refine position of spur gear B mounting screw.

**(4) Requirement**

Replace spur gear C in plate assembly. Backlash between spur gears B and C should be barely perceptible.

**To Adjust**

Refine position of spur gear C mounting screw.

**(5) Requirement**

Replace brake disc assembly. Backlash between spur gear C and its mating gear on disc assembly should be barely perceptible.

**To Adjust**

Refine requirements (4) and (5).

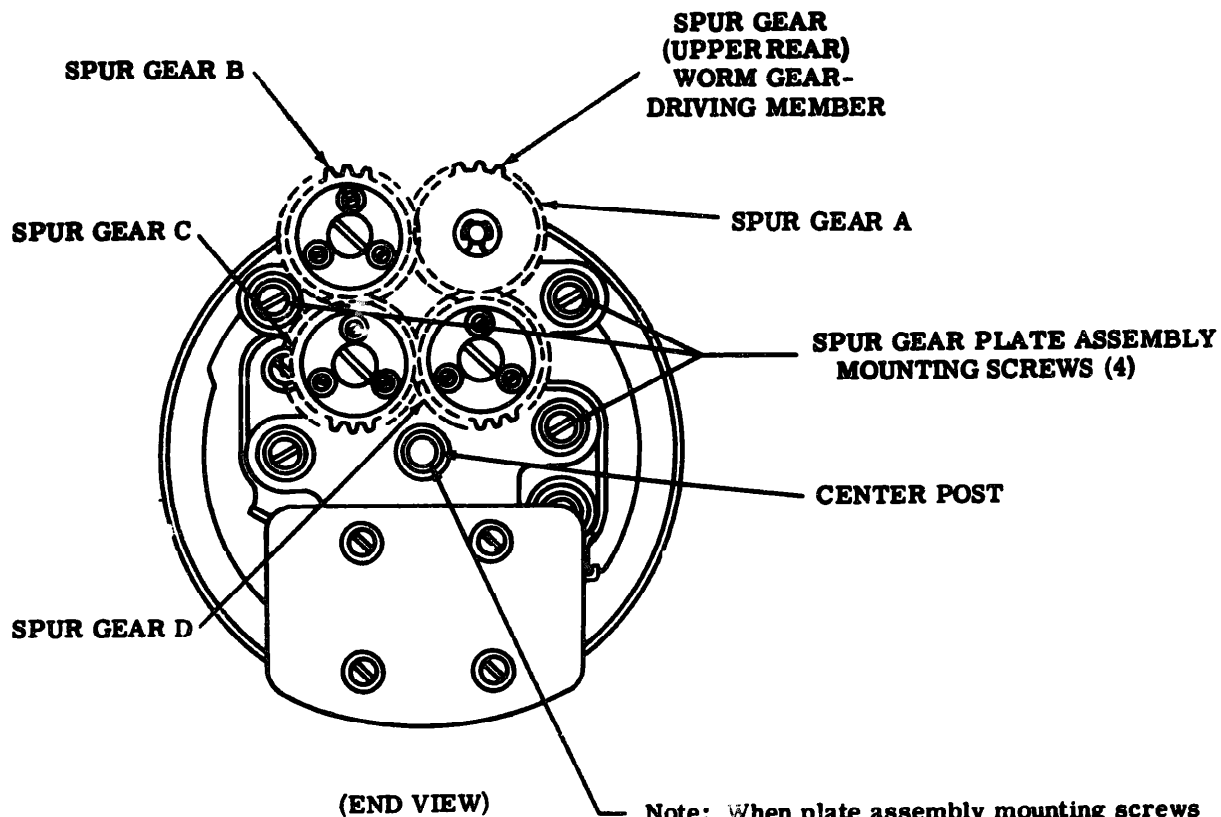
**(6) Remove the brake disc assembly and replace spur gear assembly.**

**Note:** When plate assembly mounting screws are replaced make sure center post is aligned with axis of motor shaft to avoid wobble.



3.11 **Plastic Type Axial Fan for 28 and 35 Teletypewriter Sets**

**CABLE CLAMP INTERFERENCE**

**Requirement**

When installing a plastic type axial fan or a motor with a plastic type axial fan, there may be interference between the fan and cable clamp on the typing unit.

**To Adjust**

Remove the cable clamp and tie cable up under the connector bracket and flat against the side plate to prevent possible interference with the plastic type axial fan.

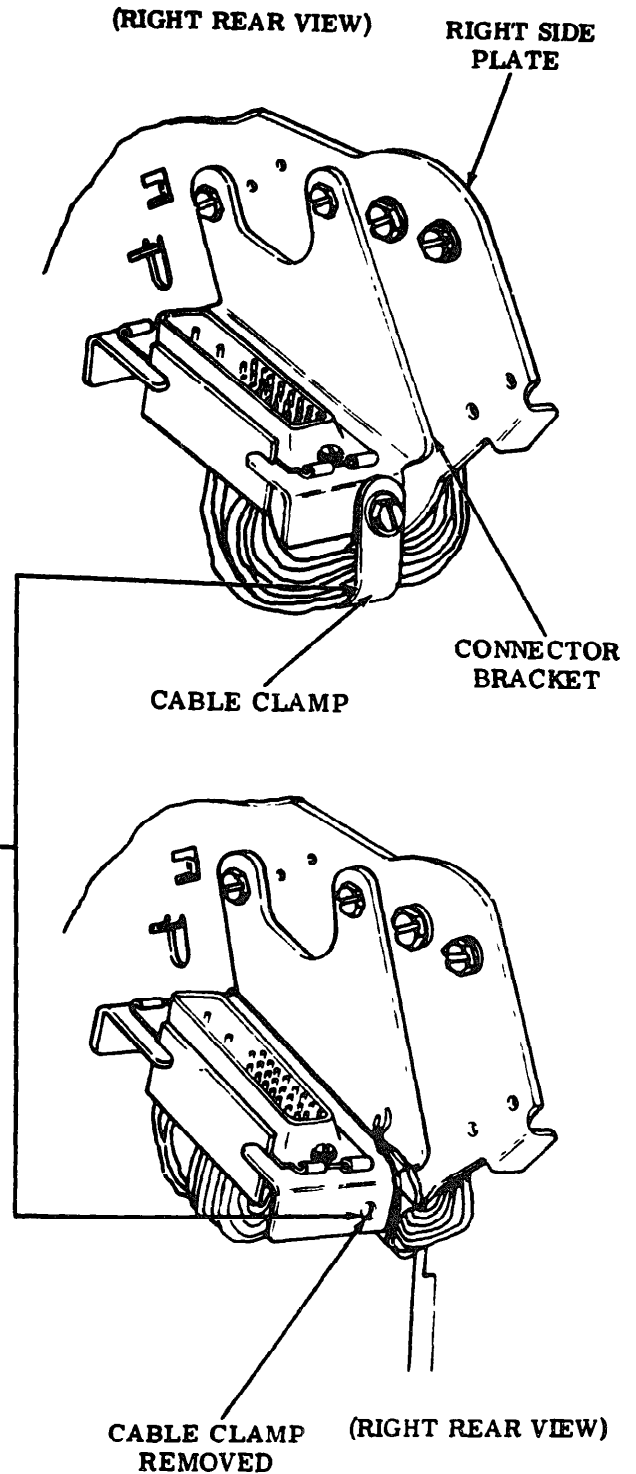

**MOTOR UNITS**

**LUBRICATION**

CONTENTS	PAGE
1. GENERAL . . . . .	1
2. LUBRICATION . . . . .	2
<b>14 AND 15 TYPE MOTOR UNITS. . . .</b>	
<b>28, 35, AND 37 TYPE MOTOR UNITS . . . . .</b>	
Motor bearings — miniature motors . . . . .	
Motor bearings — standard motors. . . . .	
<b>32 AND 33 TYPE MOTOR UNITS. . . .</b>	
Motor bearings — miniature motors . . . . .	
<b>GEAR TRAIN AND GOVERNOR. . . . .</b>	
Gear train and governor assembly. . . . .	

1. GENERAL

1.01 This section provides lubrication information for motor units used with various teletypewriters and associated apparatus. It is reissued to include engineering changes and additions, 14 and 15 type motor units, series governed motors, and variable speed gear train governor assembly. Since it is a general revision, marginal arrows used to indicate changes and additions have been omitted.

1.02 For complete lubrication of the pinion gear and intermediate gear assembly, refer to the section covering the application in which the motor is being used.

1.03 The motor ball bearings of the 28, 35, and 37 type motor units are packed with a wide range temperature lubricant by the manufacturer and normally will not require relubrication. However, if the motor is disassembled at any time, the bearings should be examined and

repacked, if required, with TKS103 grease (2.04 and 2.05). The bearings of the 32 and 33 type motors do not contain TKS103 grease and therefore must be lubricated with KS7470 oil (2.06). The lubricating interval is 750 consecutive operating hours or 3 months, whichever occurs first.

Note: The 28, 35, and 37 type motor units are furnished with ball type oilers or oil holes; however, they are not to be oiled or greased.

1.04 The exposed motor shaft should be covered with a thin film of grease to prevent rust.

1.05 The gear train and governor assembly uses KS7470 oil at all locations where the use of oil is indicated. Use KS7471 grease on all surfaces where grease is indicated.

1.06 The governor regulator gear train requires a thin film of grease on the teeth of each gear.

**CAUTION: NOTE LOCATION OF NEEDLE TYPE AND BALL TYPE BEARINGS ON GOVERNOR SPUR GEAR ASSEMBLY (2.08) AND EXERCISE CARE IN DISASSEMBLING UNIT. MAKE SURE THAT BEARINGS ARE NOT LOST OR DAMAGED AND THAT UNIT OPERATES WITHOUT BINDING WHEN ASSEMBLED.**

1.07 The governor should be lubricated after every 1500 hours of operation, or after 2000 adjustment cycles (governor speed changes using the "Slow-Fast" speed adjusting lever), whichever occurs first.

Note: Check governor brushes for wear; any accumulation of carbon dust should be removed.

1.08 The following list of symbols applies to the specific lubrication instructions shown in the line drawings:

<u>Symbol</u>	<u>Meaning</u>
02	Apply 2 drops of oil
06	Apply 6 drops of oil
G	Apply thin film of grease

## 2 . LUBRICATION

### 14 AND 15 TYPE MOTOR UNITS

2.01 Motor Bearings: Depress ball oilers (2) with nozzle of grease gun and lubricate bearings with one stroke of the plunger. Run

motor for a few minutes to work out excess grease. Stop motor and wipe off excess grease.

**CAUTION: TOO MUCH GREASE CAUSES STARTING SWITCH TROUBLE ON THE SYNCHRONOUS MOTORS, COMMUTATOR TROUBLE AND FALSE GROUNDING ON DC MOTORS, AND ON AC SERIES MOTORS.**

2.02 Motor Pinon: Apply thin film of grease to prevent rust.

2.03 Motor Speed Adjusting Lever (Governed Motors): Apply oil on pilot screw.

**28, 35, AND 37 TYPE MOTOR UNITS**

**CAUTION: DO NOT USE GREASE GUN ON MOTOR UNITS.**

**2.04 Motor Bearings — Standard Motors**

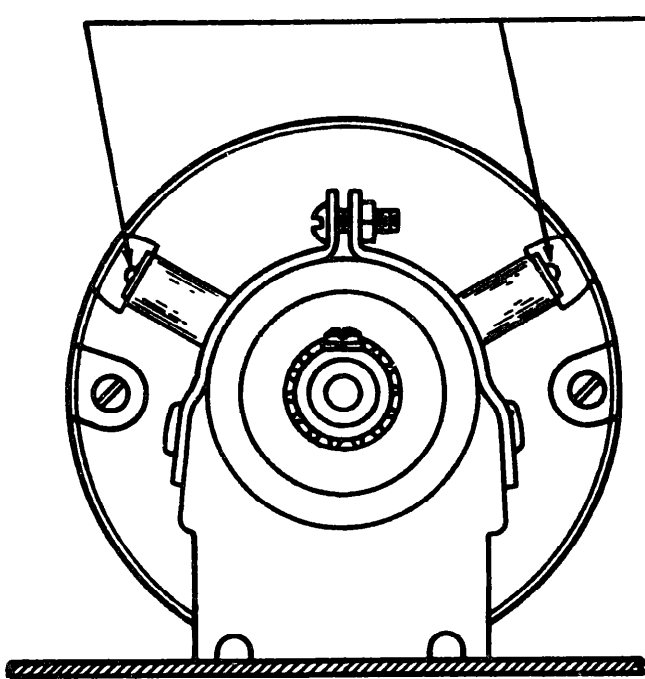

**Ball Oilers**

(Motors are furnished with ball type oilers; however, they are not to be oiled. Motor ball bearings are packed with a wide range temperature TKS103 grease.)

**2.05 Motor Bearings — Miniature Motors**

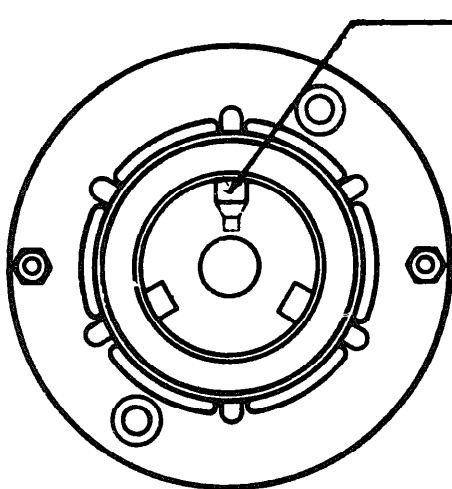

**Oil Hole**

(Motors are furnished with oil holes; however, they are not to be oiled. Motor ball bearings are packed with a wide range temperature TKS103 grease.)

**32 AND 33 TYPE MOTOR UNITS**

**2.06 Motor Bearings — Miniature Motors**

**CAUTION: DO NOT USE GREASE GUN ON MOTOR UNITS.**

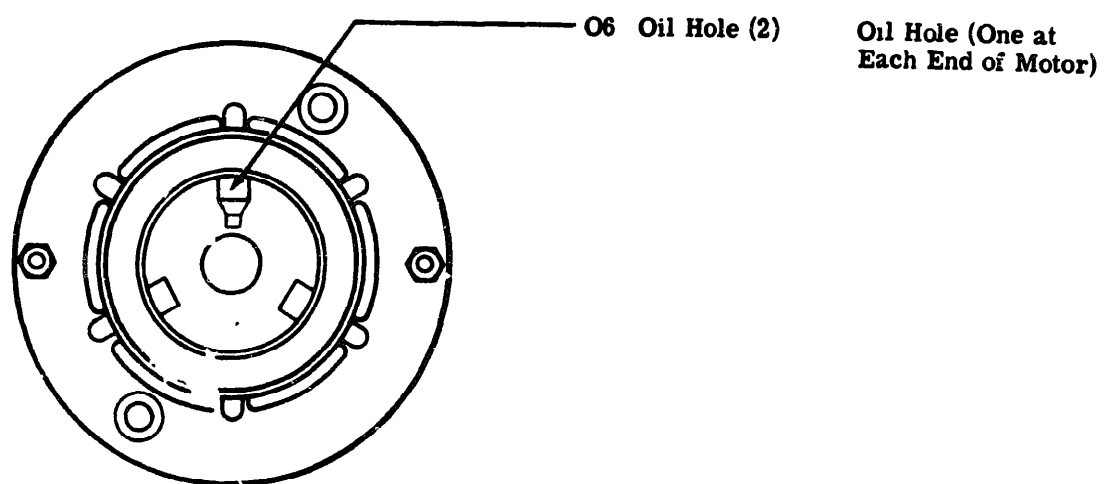

## GEAR TRAIN AND GOVERNOR

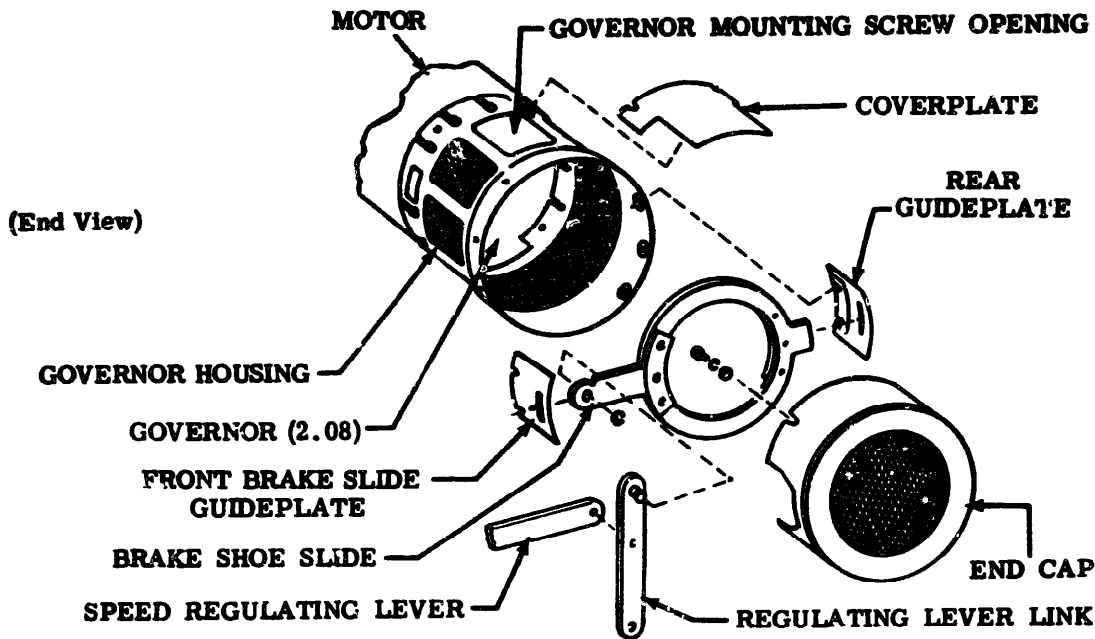

2.07 To lubricate gear train and governor assembly:

- (1) Remove end cap of governor housing with its mounting screws (4) loosened.
- (2) Remove front and rear guideplates of brake shoe slide; remove the retaining ring that secures the regulating lever link with brake shoe slide.
- (3) Remove coverplate from top of governor housing; remove governor mounting screw, and slide governor out of housing.
- (4) Remove brake discs from center shaft by removing its retaining ring and sliding disc assembly outward. Apply grease to shaft and bearing (2.08).

**CAUTION: AVOID LOSS OF NEEDLE BEARINGS IN HANDLING.**

- (5) Remove spur gear plate assembly by removing its mounting screws (4) attached to respective posts. Grease the worm gear bearing (located opposite shaft driving gear) (2.08).

**CAUTION: AVOID LOSS OF BALL BEARING IN HANDLING.**

- (6) Remove worm gear driving (spur) gear by removing retaining ring from worm gear shaft. Remove ball bearing, fill cavity with grease and replace bearing. Wipe off excessive grease and replace spur gear (2.08).

**CAUTION: EXERCISE CARE IN HANDLING BEARINGS.**

- (7) Remove remaining spur gears (3) by removing respective bearing rings. Grease upper front gear bearing and apply oil to lower left and right gear bearings as directed. Replace bearing rings (3).

- (8) Rotate worm gear manually to expose threads of spring tension adjusting screw. Grease threads inside governor spring assembly.**
- (9) Remove adjusting screw drive gear by removing its locknut and lockwasher. Grease bearing surface of spring assembly and replace parts. Push adjusting screw downward to expose bearing surface while greasing.**
- (10) Apply thin film of grease to teeth of all gears in the assembly.**
- (11) Recheck spur gear requirements given in Section 570-220-700TC, replace the spur gear plate assembly and grease the center post.**
- (12) Replace the shims on center post, slide the disc assembly in place and secure by the retaining ring.**
- (13) Check for wear of governor brushes, replace if necessary. Hold brushes away from motor shaft and slide governor assembly in place. Reposition the brushes on the slip rings.**
- (14) Replace brake shoe slide assembly and governor housing in the reverse order. Exercise care to make sure that all components move freely and all coverplates, etc are secured to shut out rfi noise.**

2.08 Gear Train and Governor Assembly

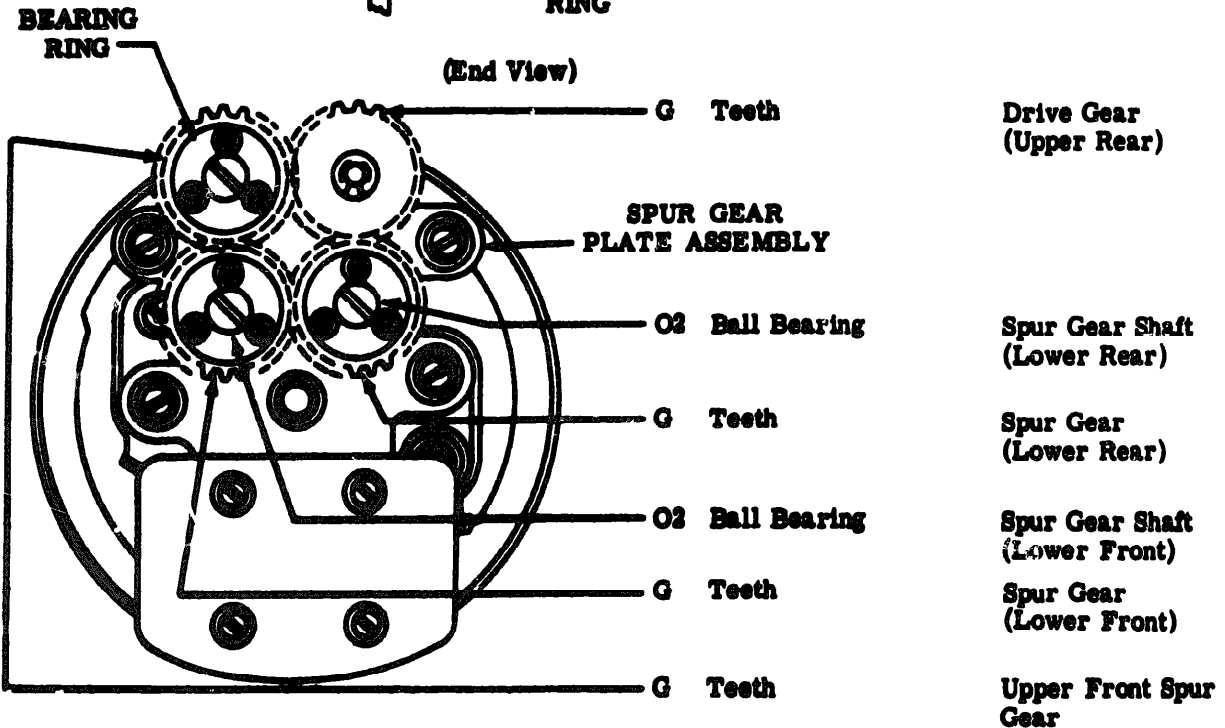
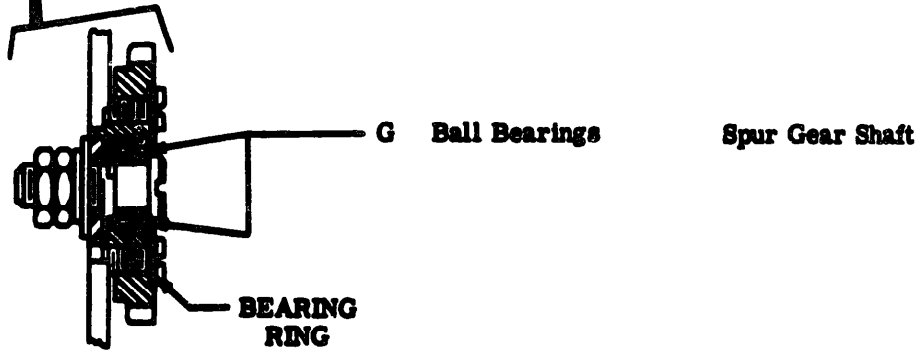
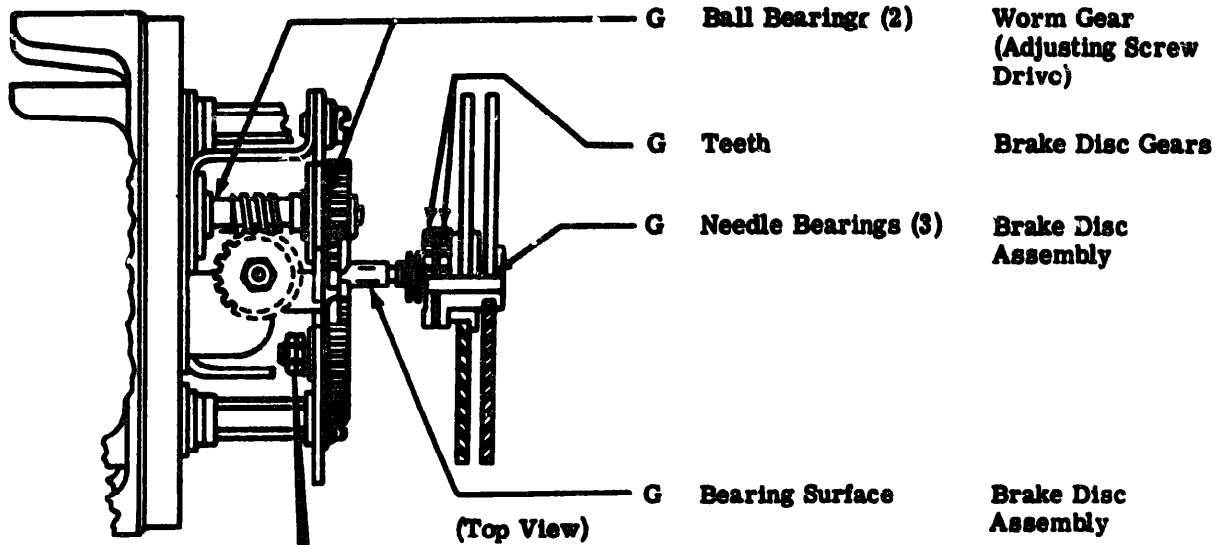



**MOTOR UNITS**

**DISASSEMBLY AND REASSEMBLY**

	CONTENTS	PAGE
1.	<b>GENERAL . . . . .</b>	1
2.	<b>MINIATURE SYNCHRONOUS MOTORS . . .</b>	1
	<b>DISASSEMBLY . . . . .</b>	1
	<b>REASSEMBLY . . . . .</b>	2
3.	<b>STANDARD AND HEAVY DUTY SYNCHRONOUS MOTORS . . . . .</b>	2
	<b>DISASSEMBLY . . . . .</b>	2
	<b>REASSEMBLY . . . . .</b>	3
4.	<b>SERIES GOVERNED MOTORS . . . . .</b>	3
	<b>DISASSEMBLY . . . . .</b>	3
	<b>REASSEMBLY . . . . .</b>	4
5.	<b>SERIES GOVERNED VARIABLE SPEED MOTORS . . . . .</b>	4
	<b>DISASSEMBLY . . . . .</b>	4
	<b>REASSEMBLY . . . . .</b>	5

1. GENERAL

1.01 This section provides the disassembly and re-assembly procedures for miniature, standard, heavy duty synchronous motor units, and series governed and series governed variable speed motor units. It is issued to describe removal and replacement of the motor units from their associated teletypewriter apparatus.

1.02 Reference should be made to the exploded views found in the appropriate parts literature for an illustration of the mechanism to be disassembled, for location and visual identification of parts, and detailed disassembly and reassembly features. Refer to maintenance tool Section 570-005-800TC for necessary tools.

1.03 When disassembling a motor unit, carefully note the location of springs, spring washers, and shims on the rotor shaft and other motor components, so that reassembly can be done correctly.

1.04 Retaining rings are made of spring steel and have a tendency to release suddenly when being removed. Loss of the retainer can be minimized as follows: Hold the retainer with the left hand to prevent it from rotating. Place the blade of a suitable screwdriver in one of the slots of the retainer. Rotate the screwdriver in a direction to increase the diameter of the retainer for removal.

1.05 To help identify the motor unit that is to be disassembled refer to Motor Unit Identification Table. First find the motor unit code number on the identification plate located on the motor bracket, then find the code number in the table. (For example: an LMU28 motor is found under the heading Series Governed Motor Units.)

2. MINIATURE SYNCHRONOUS MOTORS

DISASSEMBLY

**CAUTION: REMOVE ELECTRICAL POWER FROM SET BEFORE STARTING DISASSEMBLY.**

2.01 Remove any shaft extension or hardware attached to the motor shaft that would prevent removal of the motor unit.

2.02 Loosen screws and remove motor power line leads from base terminal block.

2.03 Remove four screws and lockwashers that secure the motor unit to the base. Lift motor unit off the

2.04 To remove the motor from its cradle bracket, loosen mounting strap screw on each end of motor and remove motor.

2.05 Loosen air duct screws and remove air duct(s) from motor.

MOTOR UNIT IDENTIFICATION TABLE

MINIATURE SYNCHRONOUS MOTOR UNITS	STANDARD AND HEAVY DUTY MOTOR UNITS	SERIES GOVERNED MOTOR UNITS	SERIES GOVERNED VARIABLE SPEED MOTOR UNITS
MU43, LMU19, LMU20, LMU24, LMU26, LMU31, LMU35, LMU45, LMU56	LMU3, LMU15, LMU21, LMU30, LMU33, LMU36, LMU37, LMU38, LMU42, LMU46, LMU49, LMU51, LMU52, LMU55, YMU2, YMU3, YMU4	LMU6, LMU13, LMU28, LMU29, LMU39, LMU41, LMU57, LMU61, LMU63, LMU64, YMU5	LMU47, LMU60

2.06 When the motor is completely removed from the mounting bracket, the remaining motor components can be removed by loosening the screws and clamps that secure them to the mounting bracket.

2.07 To remove end shields and rotor:

- (1) Remove screw and lockwasher that mount pinion to the shaft. Remove pinion from shaft.
- (2) Remove the two nuts and the two bolts that secure the end shields to the stator.
- (3) Remove the end shields. Remove the rotor and note the positioning of spring washer and shims on the rotor shaft so that the parts when replaced are positioned correctly.

**REASSEMBLY**

Note. The pinion end of the rotor is positioned opposite the leads end of the stator.

2.08 To assemble motor, reverse the disassembly procedure.

2.09 For the adjustment of motor, components, and air duct(s), refer to Section 570-220-700TC.

2.10 When replacing the motor unit on the mounting base, reverse the removal procedure given in 2.01 through 2.03, and make sure the ground strap is attached to the mounting screw.

3. STANDARD AND HEAVY DUTY SYNCHRONOUS MOTORS

**DISASSEMBLY**

**CAUTION:** REMOVE ELECTRICAL POWER FROM SET BEFORE STARTING DISASSEMBLY.

3.01 If the set contains a typing unit it must be removed to gain access to the motor unit, as follows:

- (1) Remove electrical cable connector(s) from the right side of the typing unit.
- (2) Remove four screws and lift typing unit off the base.

3.02 Remove any shaft extensions or hardware attached to the motor shaft that would prevent removal of the motor unit.

3.03 Loosen screws and remove motor power line leads from the base terminal block.

3.04 Remove four screws and lockwashers that secure the motor unit to the base. Remove motor unit from base.

3.05 To remove motor from the cradle:

- (1) Loosen mounting strap screw on each end of motor and remove motor unit.

(2) Remove the remaining motor components by loosening the screws and clamps that secure them to the mounting bracket. On some units the motor components are secured by tension springs. Unhook the ends of the springs to remove motor components.

(3) For components mounted in a compartment below the motor and secured to a mounting plate, loosen four screws and remove mounting plate. The motor components are now exposed for removal.

3.06 To remove end shields and rotor:

- (1) Remove fan from the shaft if furnished.
- (2) Remove screw and lockwasher that mount pinion to shaft. Remove pinion from shaft.
- (3) Remove the two nuts and two bolts that secure the end shields to the stator. Remove end shields, rotor, spring, and washer.

**REASSEMBLY**

**Note:** Position the spring with the tapered end down. Place washer on top of the spring in the end shield bearing recess located at the leads end of the stator. The pinion end of the rotor, which is the longest shaft end from the ball bearing, is positioned opposite to the leads end of the stator.

3.07 To reassemble motor, reverse the disassembly procedure.

3.08 For the adjustment of motor and components, refer to Section 570-220-700TC.

3.09 When replacing the motor unit on the base, reverse the removal procedure shown in 3.01 through 3.04, and make sure the ground strap is attached to the mounting screw.

4. SERIES GOVERNED MOTORS

**DISASSEMBLY**

**CAUTION:** REMOVE ELECTRICAL POWER FROM SET BEFORE STARTING DISASSEMBLY.

Remove the typing unit from the base to gain access to the motor unit, as follows:

- (1) Remove electrical cable connector(s) from the right side of typing unit.
- (2) Remove four screws and lift typing unit off the base.

4.02 Remove gear guard and connections that prevent removal of motor unit.

4.03 Loosen screws and remove motor power line leads from base terminal block.

4.04 Remove four screws and lockwashers that secure the motor mounting bracket to the base and lift motor unit off the base.

4.05 Remove four screws that secure the screened cover on the motor end. Remove cover.

**Note:** To avoid damaging the screen do not grip cover over screened openings.

4.06 Remove two screws on the rear face of governor cover. Remove governor cover.

4.07 To remove governor, remove screw and lockwasher that is threaded through the shaft.

4.08 Remove motor brush caps and motor brushes. The positioning of each brush should be noted or marked so that each brush may be inserted in the same holder with the same side up. Make sure the insulators are kept inside each of the brush caps.

4.09 Loosen mounting strap on governor end and unhook from cradle. Do not remove mounting strap. Loosen and remove mounting strap on opposite end of motor. Remove motor from cradle.

**Note:** In some units the motor can be removed from the cradle for only a short distance due to the length of the cable stored in the bracket compartment.

4.10 To remove end shield and armature:

(1) Remove screw and lockwasher that mount pinion to the shaft. Remove pinion from shaft.

(2) Remove the two nuts and lockwashers securing the end shield to the stator.

(3) When removing the end shield, it may be necessary to pry it loose from the stator.

(4) Remove the armature. Remove the washers and spring that are found in the end shield bearing recess on the governor end. The spring is positioned with the tapered end in the end shield bearing recess with the washers on top of the spring.

**REASSEMBLY**

4.11 Hold motor in upright position being careful not to damage governor brushes. Place tapered end of spring downward into bearing recess and place washers on top of the spring.

**Note:** Before pushing armature shaft completely through end shield on governor end, the governor brushes must be pushed into their respective spring loaded brush holders and held depressed so that armature shaft can clear the brushes.

4.12 Place armature into stator with commutator end down and make sure the armature shaft clears the governor brushes as indicated in note (4.11).

4.13 Assemble end shield with ball oilers in line with oilers on governor end. Most of the motor units have ball oilers positioned upward (opposite leads out location). For inverted mounting, ball oilers are positioned downward (same side as leads out location). Place washer and nut on each end shield bolt. Tighten nuts.

4.14 Place motor on cradle mounting bracket and position both mounting straps making sure the mounting strap screw heads face to the right while viewing the governor end. Tighten mounting strap screws. Check tightness of both screws on governor brush terminals.

4.15 Replace motor brushes making sure they are properly assembled (see 4.08). Insulators must be in brush caps. The pigtails of the brushes should be free from kinks and move freely in the spring coils.

4.16 When replacing the governor, retract each carbon brush as the governor is pushed on the shaft. Align the hole in the flat side of the governor hub with the threaded hole in the shaft. Place lockwasher and screw through governor hub hole and thread into the shaft. Tighten screw.

**Note:** Make sure the governor brush leads do not interfere with governor fins. Push leads down to allow ample clearance. Position each brush pigtail terminal to allow free travel of the brush in its guide.

4.17 For the adjustments of motor and components refer to Section 570-220-700TC.

4.18 Assemble governor cover and tighten both screws.

4.19 Replace screened cover and tighten four screws.

**Note:** To avoid damaging the screen, do not grip cover over screened openings.

4.20 Assemble motor unit to mounting base as follows:

- (1) Place motor unit on mounting base.
- (2) Assemble ground strap and four mounting screws to base. Tighten screws.

4.21 Replace typing unit and four mounting screws. Tighten screws.

4.22 Replace electrical cable connector(s) on right side of typing unit.

5. SERIES GOVERNED VARIABLE SPEED MOTORS

DISASSEMBLY

**CAUTION:** REMOVE ELECTRICAL POWER FROM SET BEFORE STARTING DISASSEMBLY.

5.01 Remove the typing unit from the base to gain access to motor unit, as follows:

- (1) Remove electrical cable connector(s) from the right side of typing unit.
- (2) Remove four screws and lift the typing unit off the base.

5.02 Remove the retaining ring and stud from brake shoe slide.

5.03 Remove gear guard and connections that would prevent removal of motor assembly.

5.04 Loosen screws and remove motor power line leads from base terminal block.

5.05 Remove four screws and lockwashers that secure the motor unit to the base. Remove the motor unit from the base.

5.06 Remove the governor screened end cap by loosening but not removing the four screws.

5.07 To remove governor brake shoe assembly, loosen but do not remove the two screws on the front brake guide and the rear brake guide. Remove governor brake shoe assembly.

5.08 Remove access plate from governor cover by loosening two screws.

5.09 To remove governor gear train assembly, use access hole to locate screw by rotating the shaft. Remove screw and lockwasher. Remove governor gear train assembly.

- 5.10 Remove four screws and lockwashers around the screened cover. Remove screened cover.
- 5.11 Remove motor brush caps and motor brushes. The position of each brush should be noted or marked so that each brush may be inserted in the same holder with the same side up. Make sure the insulators are kept inside the brush caps.
- 5.12 Loosen mounting strap on governor end and unhook from cradle, but do not remove mounting strap. Loosen and remove mounting strap on opposite end of motor.
- 5.13 Motor units that do not have their motor components soldered to the bracket compartment may be completely removed by loosening the motor components mounting screws, lockwashers, and clamps.
- 5.14 To remove end shield and armature:
- (1) Remove pinion screw and lockwasher. Remove pinion from shaft.
  - (2) Remove the two nuts and lockwashers securing the end shield to the stator.
  - (3) When removing the end shield it may be necessary to pry it loose from the stator.
  - (4) Remove the armature. Remove the washers and spring that are nested in the end shield bearing recess on the governor end. The spring is positioned, tapered end down, with washer on top of the spring.

#### REASSEMBLY

- 5.15 Hold motor in upright position being careful not to damage governor brushes. Place tapered end of spring downward into bearing recess and place washers on top of spring.
- Note: Before pushing armature shaft completely through end shield on governor end, the governor brushes must be pushed into their respective spring loaded brush holders and held depressed so that armature shaft can clear the brushes.
- 5.16 Place armature into stator with commutator end down and make sure the armature shaft clears the governor brushes as indicated in note (5.15).
- 5.17 Assemble end shield with ball oilers in line with ball oilers on governor end. Place lockwashers and nuts on end shield bolts. Tighten nuts.
- 5.18 Place motor on cradle and position both mounting straps making sure the mounting strap screw heads face to the right while viewing the governor end. Tighten mounting strap screws. Check tightness of both screws on governor brush terminals.
- 5.19 Replace pinion on shaft with lockwasher and screw. Tighten screw.
- 5.20 Replace motor brushes making sure they are properly assembled (5.11). Insulators must be in brush caps. The pigtails of the brushes should be free from kinks and move freely in the spring coils.
- 5.21 Replace screened cover with access hole facing up (opposite from leads out location in motor).
- 5.22 When replacing governor gear train assembly, retract each carbon brush as governor is pushed on the shaft. Align the hole in the flat side of the governor hub with the threaded hole in the shaft. Use a tweezer to position lockwasher and screw. Tighten screw.
- Note: Make sure the governor brush leads do not interfere with governor fins. Push leads down to allow ample clearance. Position each brush pigtail terminal to allow free travel of the brush in its guide.
- 5.23 For the adjustments of motor and components refer to Section 570-220-700TC.
- 5.24 Position access plate on screened cover and replace four screws, lockwashers, and flat washers. Tighten
- 5.25 Replace brake shoe slide assembly with brake slide lever to the left while viewing governor end. Tighten the screws on the front brake guide and rear brake guide friction tight. Make sure governor gear train assembly clears the governor shoes by rotating motor shaft. Adjust brake guides if required. Tighten the screws on front and rear
- 5.26 Replace governor screened end cap and tighten screws.
- 5.27 To assemble motor unit to mounting base:
- (1) Place motor unit on mounting base.
  - (2) Assemble ground strap and four mounting bolts to base. Tighten mounting bolts.
- 5.28 Align the hole in the brake slide lever and link. Assemble stud and retainer ring.
- 5.29 Replace typing unit and four mounting screws. Tighten screws.
- 5.30 Replace electrical cable connector(s) on the right side of the typing unit.

**MOTOR UNIT (MU, LMU AND YMU)  
PARTS**

FIGURE	CONTENTS	PAGE
1	Motor Unit Application Chart	2
2	Synchronous Motor Cross-Reference Chart	3
3	Synchronous Motor Assemblies (Standard or Heavy Duty)	4
4	Relay and Capacitor Mounting (Synchronous)	5
5	Relay and Capacitor Mounting (Synchronous)	6
6	Relay and Capacitor Mounting	7
7	Relay and Capacitor Mounting (Synchronous)	8
8	Relay and Capacitor Mounting (Synchronous)	9
9	Synchronous Motor Assemblies (Miniature)	10
10	Relay and Capacitor Mounting (Synchronous)	11
11	Relay, Capacitor Mounting and Bracket (Synchronous)	12
12	Synchronous Motor Mounting with Centrifugal Switch Assembly	13
13	Relay and Capacitor Mounting (Synchronous)	14
14	Series Motor Cross-Reference Chart	15
15	Series Motor Assemblies	16
16	Brush Assemblies	17
17	150845 and 324116 Governor Assemblies	18
18	154628 Governor Assembly	19
19	Series Motor Mounting Parts	20
20	Series Motor Mounting Parts with RF Suppression	21
21	Series Motor Mounting Parts with RF Suppression	22
22	Series Motor Mounting Parts	23
23	Series Motor Mounting Parts with RF Suppression	24
24	Series Motor Mounting Parts with RF Suppression	25
25	174546 Modification Kit to Provide Motor Running Contacts	26
26	174551 (less cable) 175198 (with cable) Modification Kits to Provide Motor Running Contacts	26
27	Triac Switch	27
28	Motor Covers	27
	Modification Kits	28
	Modification Kits (Continued)	29
	Numerical Index	30

Units Covered	Operating Characteristics	General Usage	ASR Set	RT Set	High Speed Punch	High Speed Reader	Miniature Trans-Dist. Miniature Reperf.	Miniature Rec. Selector	Compact Page Printer	Tape Printer (Ticker)	Multiple Mounted Units	Variable Speed	Stack Mounted	Wall Mounted	37 Type
Teletype Code															
LMU3	AC Synchronous, 1/20 HP, 115V/60 Hertz/3600RPM	X													
LMU4	Series, 1/20 HP, 115V/60 Hertz/3600 RPM, RF Sup.	X													
LMU6	Series, 1/20 HP, 115V/60 Hertz/3600 RPM	X													
ⓄLMU10	Series, 1/20 HP, 115V/60 Hertz/3600 RPM, RF Sup.											X			
LMU11	AC Synchronous, 1/12 HP, 115V/60 Hertz/3600 RPM			X											
LMU12	AC Synchronous, 1/12 HP, 115V/60 Hertz/3600 RPM		X								X				
LMU13	Series, 1/15 HP, 115V/60 Hertz/3600 RPM			X											
LMU14	Series, 1/15 HP, 115V/60 Hertz/3600 RPM, RF Sup.		X								X				
LMU15	AC Synchronous, 1/20 HP, 115V/60 Hertz/3600 RPM	X													
LMV19	AC Synchronous, 25 MHP, 115V/60 Hertz/3600 RPM						X								
LMU20	AC Synchronous, 25 MHP, 115V/60 Hertz/3600 RPM							X							
LMU21	AC Synchronous, 1/20 HP, 115V/60 Hertz/3600 RPM												X		
LMU23	DC Series, 1/15 HP, 48V/3600 RPM			X											
LMU24	AC Synchronous, 25 MHP, 115V/60 Hertz/3600 RPM							X							
LMU26	AC Synchronous, 25 MHP, 115V/60 Hertz/3600 RPM							X	X						
LMU27	AC Synchronous, 1/20 HP, 115V/60 Hertz/3600 RPM													X	
LMU28	Series, 1/20 HP, 115V/60 Hertz/3600 RPM												X		
LMU29	DC Series, 1/15 HP, 48V/3600 RPM	X													
LMU30	AC Synchronous, 1/20 HP, 115V/60 Hertz/3600 RPM			X											
LMU31	AC Synchronous, 25 MHP, 115V/60 Hertz/3600 RPM							X							
LMU32	Series, 1/15 HP, 115V/60 Hertz/3600 RPM, RF Sup.			X											
LMU33	AC Synchronous, 1/20 HP, 115V/50 Hertz/3000 RPM				X										
LMU35	AC Synchronous, 25 MPH, 115V/50 Hertz/3000 RPM					X									
LMU36	AC Synchronous, 1/20 HP, 115V/50 Hertz/3000 RPM			X											
LMU37	AC Synchronous, 1/20 HP, 115V/60 Hertz/3600 RPM								X						
LMU38	AC Synchronous, 1/20 HP, 115V/50 Hertz/3000 RPM	X													
LMU39	Series, 1/15 HP, 115V/60 Hertz/3600 RPM, RF Sup.		X								X				
LMU41	Series, 1/20 HP, 115V/60 Hertz/3600 RPM, RF Sup.	X	X												
LMU42	AC Synchronous, 1/20 HP, 115V/60 Hertz/3600 RPM									X					
LMU43	AC Synchronous, 25 MHP, 115V/60 Hertz/3600 RPM														
LMU45	AC Synchronous, 25 MHP, 115V/60 Hertz/3600 RPM					X									
LMU46	AC Synchronous, 1/20 HP, 115V/60 Hertz/3600 RPM				X										
ⓄLMU47	Series, 1/20 HP, 115V/60 Hertz/3600 RPM, RF Sup.												X		
LMU49	AC Synchronous, 1/20 HP, 115V/60 Hertz/3600 RPM	X													
LMU50	AC Synchronous, 1/12 HP, 115V/50 Hertz/3000 RPM		X												
LMU51	AC Synchronous, 1/20 HP, 115V/50 Hertz/3000 RPM								X						
LMU52	AC Synchronous, 1/20 HP, 115V/50 Hertz/3000 RPM												X		
LMU55	AC Synchronous, 1/20 HP, 230V/50 Hertz/3000 RPM	X													
LMU56	AC Synchronous, 25 MPH, 115V/60 Hertz/3600 RPM							X							
LMU57	Series, 1/20 HP, 115V/60 Hertz/3600 RPM	X													
LMU60	Series, 1/20 HP, 115V/60 Hertz/3600 RPM											X			
LMU61	Series, 1/15 HP, 115V/60 Hertz/3600 RPM		X												
LMU63	Series, 1/20 HP, 115V/60 Hertz/3600 RPM, RF Sup.	X													
LMU64	Series, 1/20 HP, 115V/60 Hertz/3600RPM, RF Sup.												X		
YMU2	AC Synchronous, 1/20 HP, 115V/60 Hertz/3600 RPM														X
YMU3	AC Synchronous, 1/20 HP, 115V/60 Hertz/3600 RPM														X
YMU4	AC Synchronous, 1/20 HP, 115V/60 Hertz/3600 RPM														X
YMU5	Series, 1/15 HP, 115V/60 Hertz/3600 RPM														X

Ⓞ Requires 173518 Modification Kit for special variable speed appl

FIGURE 1. MOTOR UNIT APPLICATION CHART

SYNCHRONOUS MOTOR UNITS

Teletype Code	Motor Assembly	Motor Bracket	Mounting Plate	Thermostat Switch	Fixed Capacitor	Starting Comp	Relay	Relay Insulator	Spring or Clamp	Cable Assembly	Jumper
LMU3	151795	305661	305660	122249	122245	305658	151923	305659	305658	151927	96264R (5" lg. Red)
LMU11	155595	305661	305660	160304	160299	305658	160303	305659	305658	151927	96264R (5" lg. Red)
LMU12	159739	305661	305660	150304	160299	305658	160303	305659	305658	151927	96264R (5" lg. Red)
LMU15	170764	305661	305660	122249	122245	305658	151923	305659	305658	151927	96264R (5" lg. Red)
LMU19	161984	142589		174471	162072	151922	173425	162196	151925	161099	96264R (5" lg. Red)
LMU20	161994	142589		174471	162072	151922	173425	162196	160302	162911	96264R (5" lg. Red)
LMU21	151795	164612		122249	122245	151922	151923	164603	151925	151927	96264R (5" lg. Red)
LMU24 and LMU56	310295	142589		fused	162072	151922	173425	162196	151925		176137 (9-1/4" lg. Black w 320410(Terminal)) 96264R (5" lg. Red)
LMU26	161984	142589		174471	162072	151922	173425	162196	160302	162911	96264P (5" lg. Red)
LMU27	178500	176948	176947	122249	122245	151922	151923	151924	151925		
LMU30	178500	305661	305660	122249	122245	305658	151923	305659	305658	151927	96264R (5" lg. Red)
LMU31	161984	142589		174471	162072	151922	173425	162196	151925	179016	96274R (10" lg. Red)
LMU33	170764	305661	305660	①193781	122245	305658	151923	305659	305658	151927	96264R (5" lg. Red)
②LMU35	194924	171749		fused	①195172	171702	①195173	171704	171703	195179	
LMU36	178500	305661	305660	①193781	122245	305658	151923	305659	305658	151927	96264R (5" lg. Red)
LMU37	151795	194897		122249	122245	151922	151923	310341	151925	194899	96264R (5" lg. Red)
LMU38	151795	305661	305660	①193781	122245	305658	151923	305659	305658	151927	96264R (5" lg. Red)
LMU42	196830	196839		122249	122245	151922	151923	196774	151925	151927	96264R (5" lg. Red)
LMU43	161984	171749		174471	162072	171702	173425	171704	171703	171810	96264R (5" lg. Red)
LMU45	161984	171749		174471	162072	171702	173425	171704	171703	193181	
LMU46	151795	305661	305660	122249	122245	305658	151923	305659	305658	193236	96264R (5" lg. Red)
LMU49	170764	172795	151920	122249	122245	151922	151923	151924	151925	151927	96264R (5" lg. Red)
③LMU50	199718	304538	151920	307281	304793	151922	304792		304537	151927	312573 (6" lg. Red w 320418(Terminal)) 312574 (6" lg. Black w 320418(Terminal))
LMU51	151795	194897		①193781	122245	151922	151923	310341	151925	194899	96264R (5" lg. Red)
LMU52	151795	164612		①193781	122245	151922	151923	164603	151925	151927	96264R (5" lg. Red)
LMU55	306063	305661	305660	320269	320270	305658	320271	305659	305658	151927	96264R (5" lg. Red)
YMU2	170764	312979		122249	122245	151922	151923	312977	151925	306320	96262R (4" lg. Red)
YMU3	170764	312979		334877	122245	151922	151923	312977	151925	306320	96262R (4" lg. Red)
YMU4	170764	305661	305660	122249	122245	305658	151923	305659	305658	306320	96274 (10" lg. Red)

① For use with motor unit operating on 50 Hertz current  
② See page 10 for parts peculiar to LMU35  
③ See page 6 for parts peculiar to LMU50

FIGURE 2. SYNCHRONOUS MOTOR CROSS- REFERENCE CHART



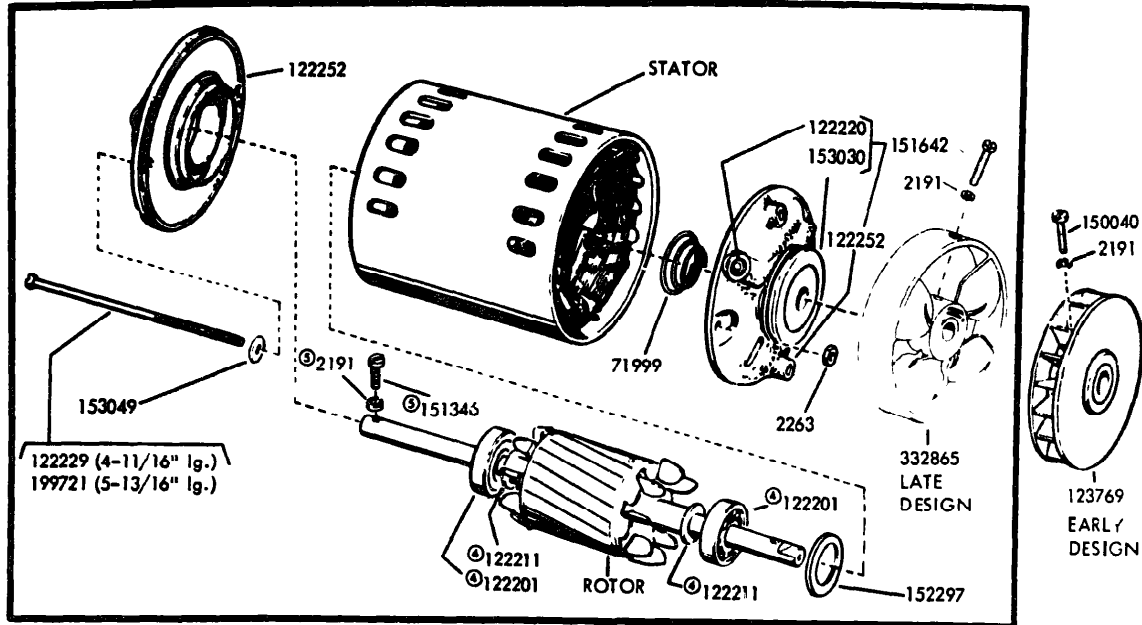

SYNCHRONOUS MOTOR ASSEMBLY - STANDARD OR HEAVY DUTY

SYNCHRONOUS MOTORS - Standard or Heavy Duty				
DUTY	MOTOR ASSEMBLY	STATOR	ROTOR	MOTOR DATA
Standard	151795	122251	128874	AC Synchronous, 1/20 HP, 115V. 50/60 Hertz, 3000/3600 RPM
Heavy	155595	①160306	160305	AC Synchronous, 1/12 HP, 115V. 60 Hertz, 3600 RPM
Heavy	159739	160306	160305	AC Synchronous, 1/12 HP, 115V. 60 Hertz, 3600 RPM
Standard	①170764	122251	②128874	AC Synchronous, 1/20 HP, 115V. 50/60 Hertz, 3000/3600 RPM
Standard	178500	③122251	④128874	AC Synchronous, 1/20 HP, 115V. 60 Hertz, 3600 RPM
Standard	⑤196830	196831	⑥128874	AC Synchronous, 1/20 HP, 115V. 60 Hertz, 3600 RPM
Heavy	199713	199720	199719	AC Synchronous, 1/12 HP, 115V. 50 Hertz, 3000 RPM
Standard	306063	320272	⑦128874	AC Synchronous, 1/20 HP, 230V. 50/60 Hertz, 3000/3600 RPM

- ① Without fan
- ② CW rotation (all others CCW rotation)
- ③ Arranged for inverted mounting
- ④ Common to all rotors
- ⑤ Not part of motor assemblies
- ⑥ New style has flat at end of rotor shaft

FIGURE 3. SYNCHRONOUS MOTOR ASSEMBLIES (STANDARD OR HEAVY DUTY)

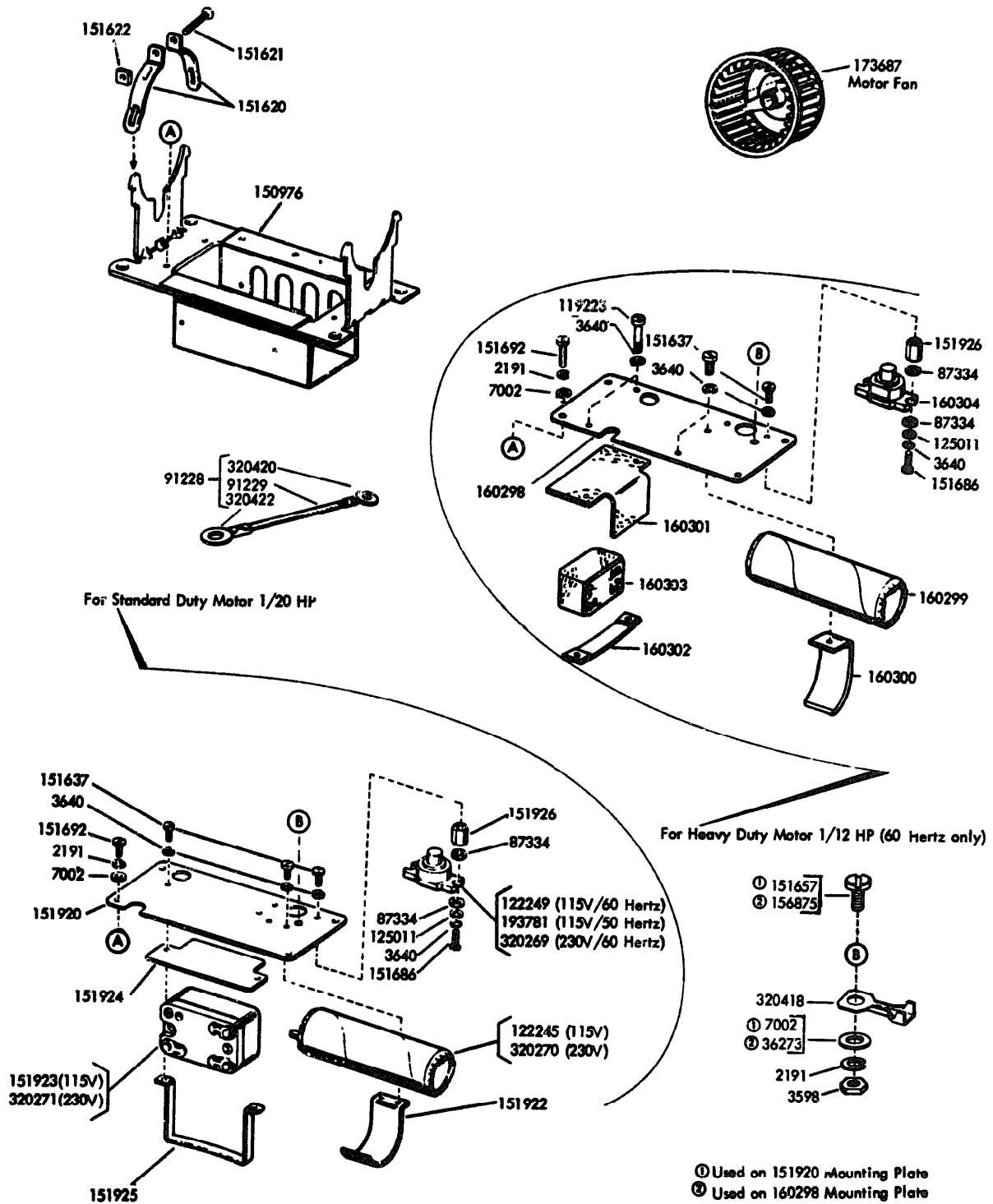

FIGURE 4. RELAY AND CAPACITOR MOUNTING (SYNCHRONOUS)

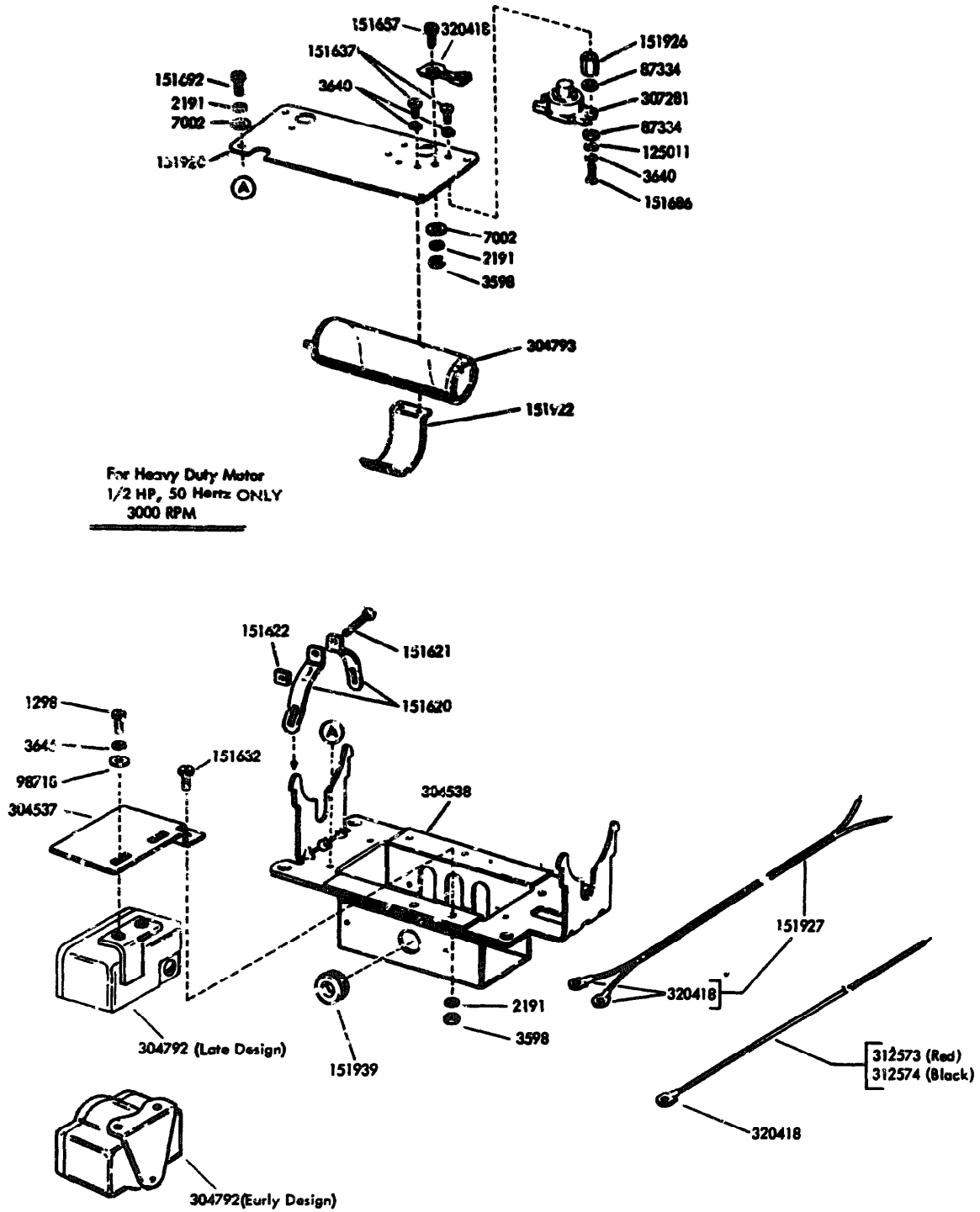

FIGURE 5. RELAY AND CAPACITOR MOUNTING (SYNCHRONOUS)

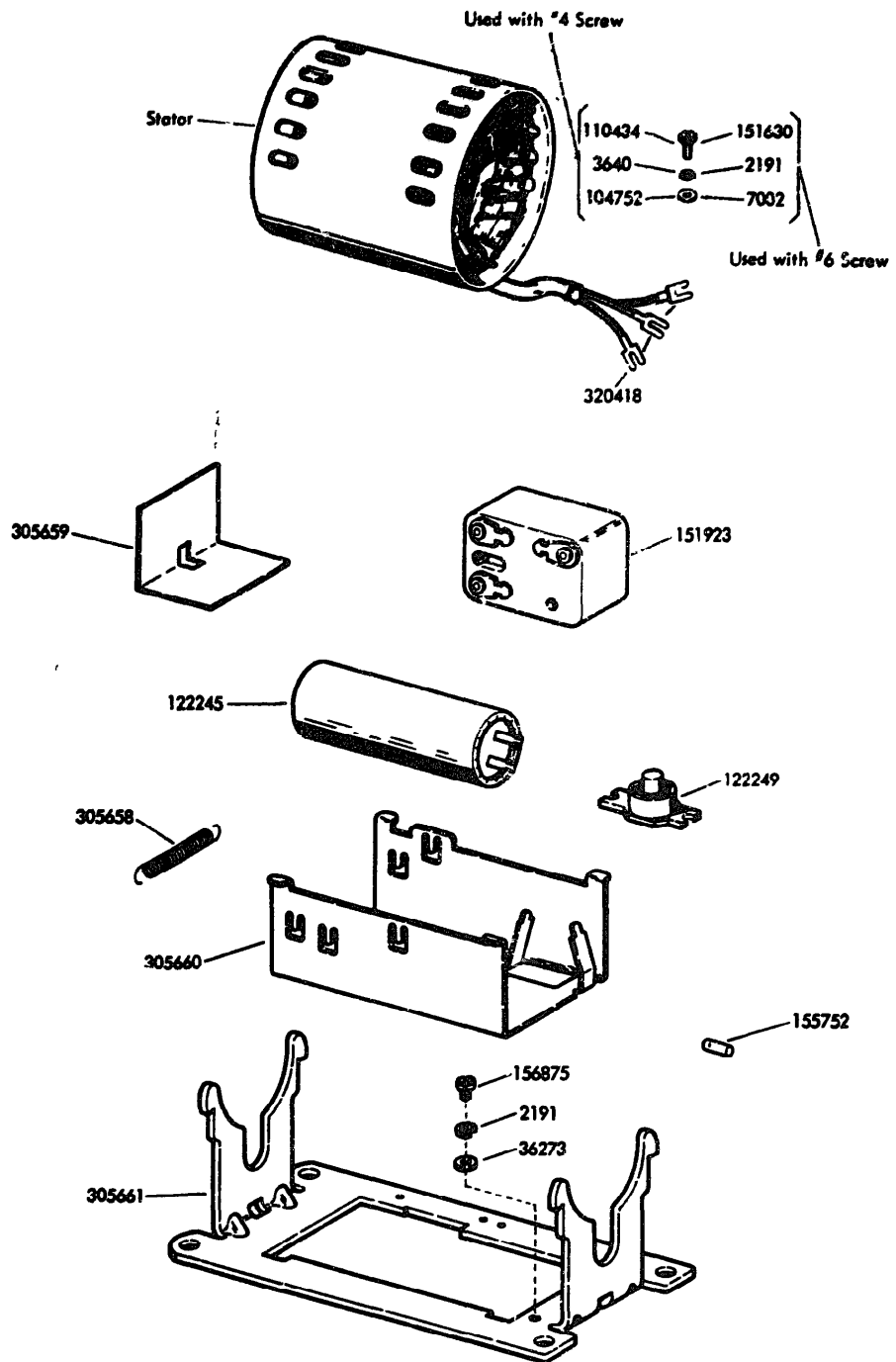

FIGURE 6. RELAY AND CAPACITOR MOUNTING

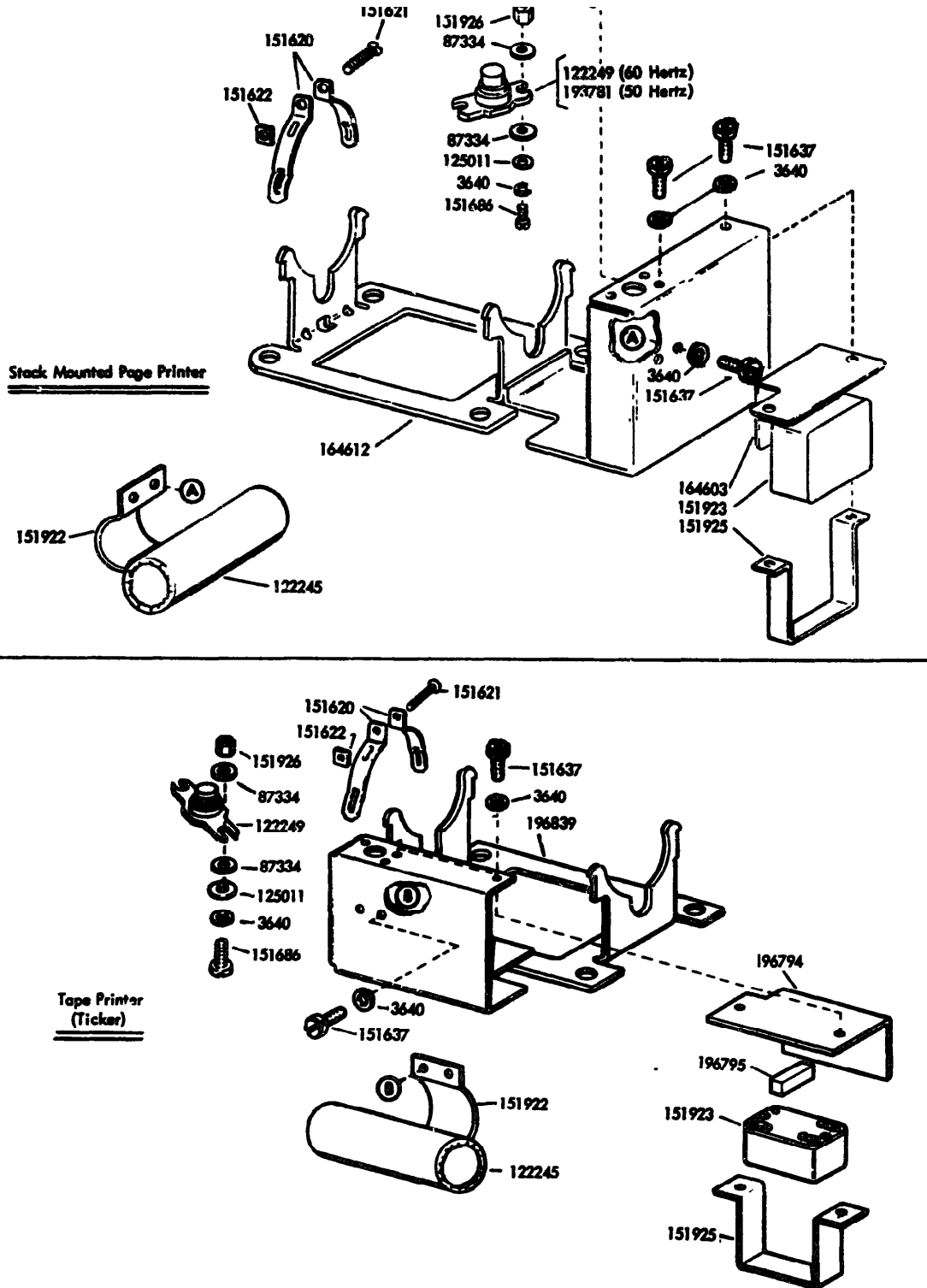
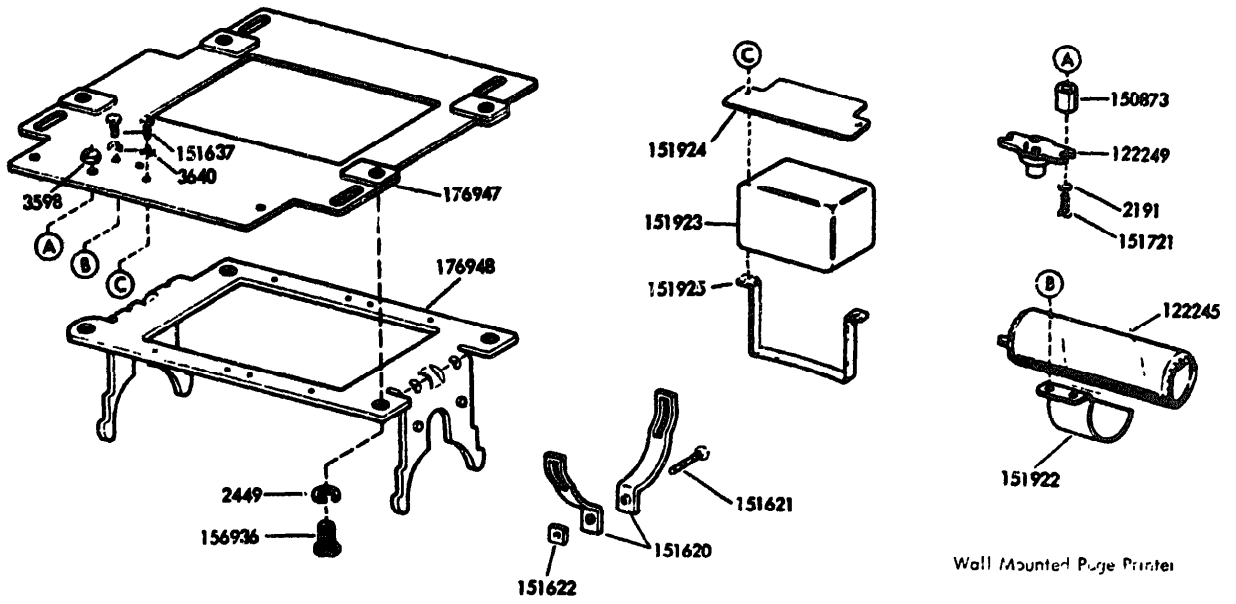
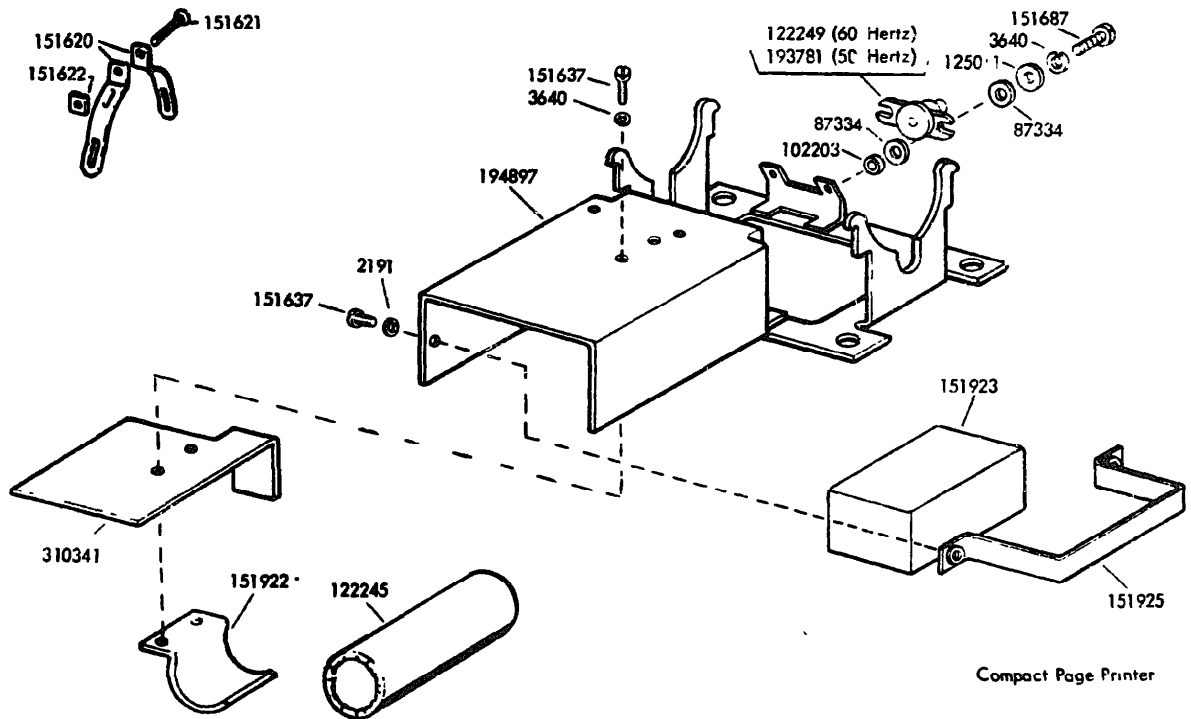

FIGURE 7. RELAY AND CAPACITOR MOUNTING (SYNCHRONOUS)



Wall Mounted Page Printer



Compact Page Printer

FIGURE 8. RELAY AND CAPACITOR MOUNTING (SYNCHRONOUS)

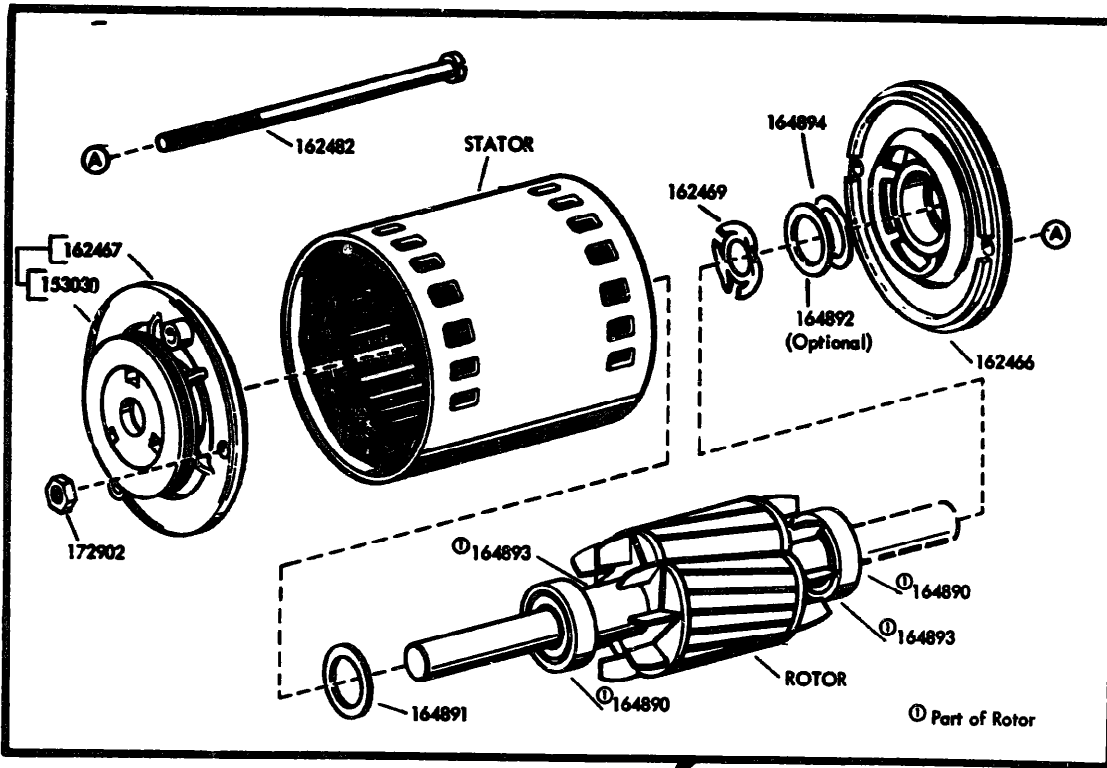

MINIATURE MOTOR ASSEMBLY

SYNCHRONOUS MOTORS - Miniature			
MOTOR ASSEMBLY	STATOR	ROTOR	MOTOR DATA
161984	162464	330564	AC Synchronous, 25 MHP, 115V: 60 Hertz, 3600 RPM
194924	195214	330564	AC Synchronous, 25 MHP, 115V: 50 Hertz, 3000 RPM
310295	162464	②330565	AC Synchronous, 25 MHP, 115V: 60 Hertz, 3600 RPM

② Has double shaft extension

FIGURE 9. SYNCHRONOUS MOTOR ASSEMBLIES (MINIATURE)

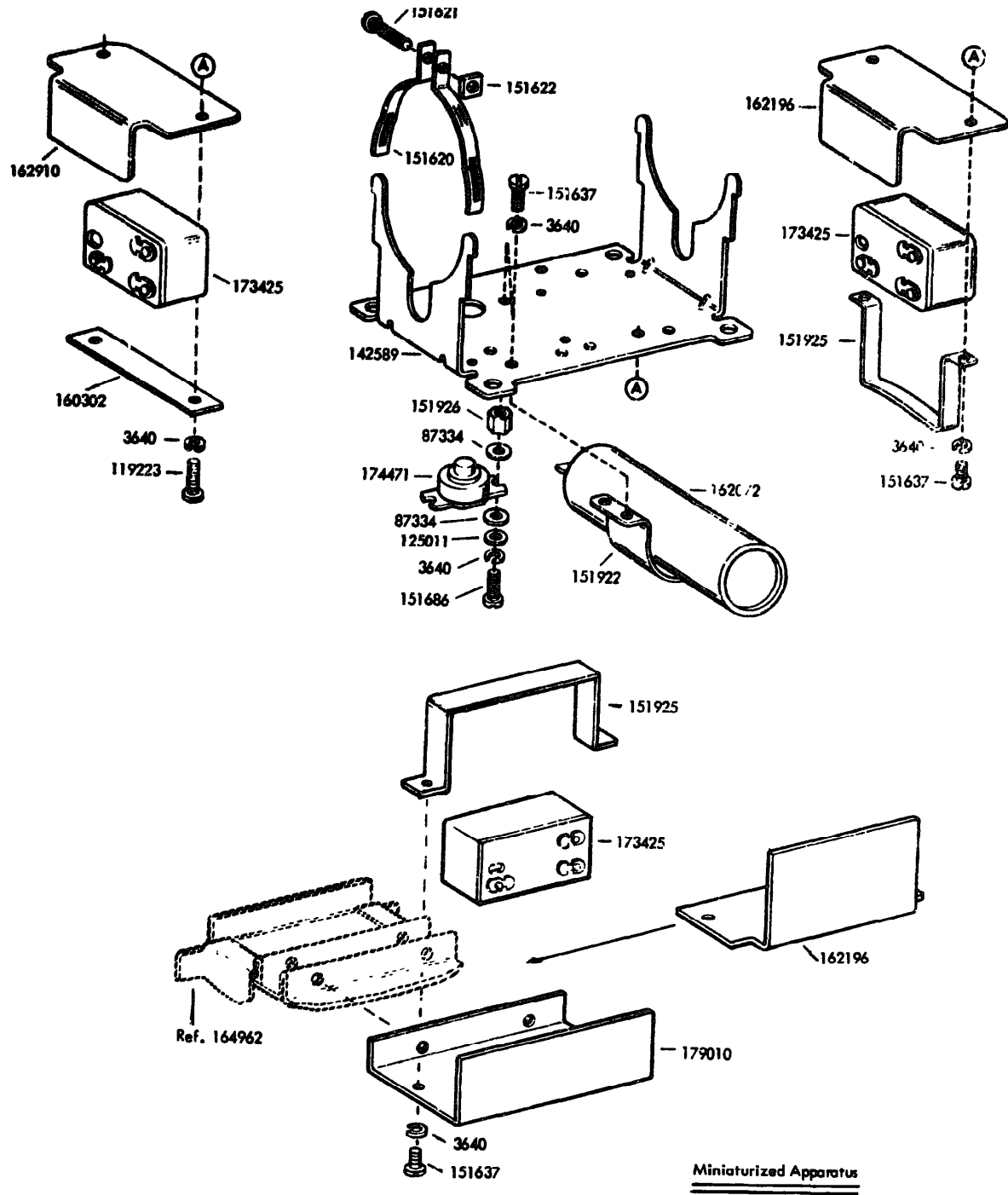

FIGURE 10. RELAY AND CAPACITOR MOUNTING (SYNCHRONOUS)



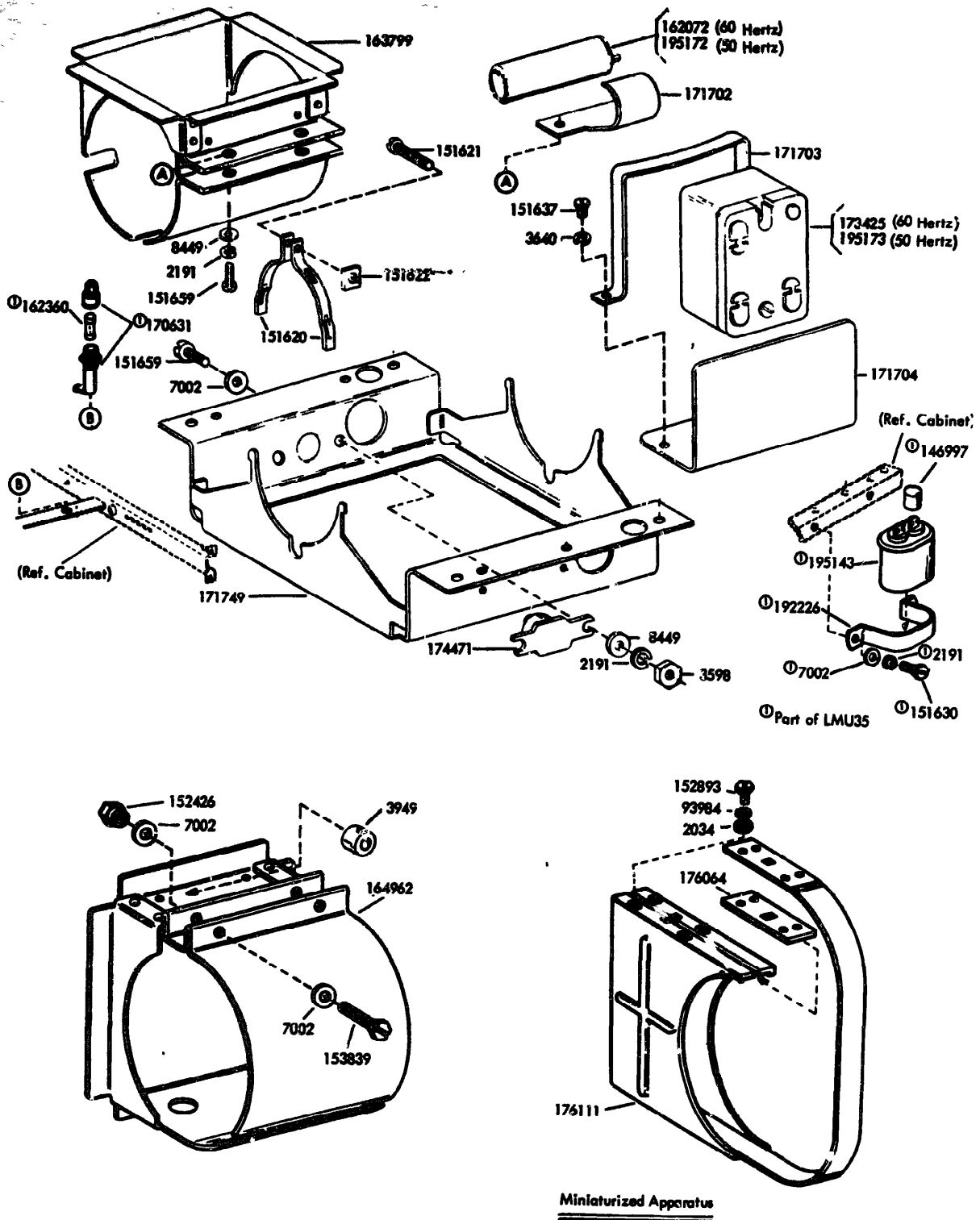

FIGURE 11. RELAY, CAPACITOR MOUNTING AND BRACKET (SYNCHRONOUS)

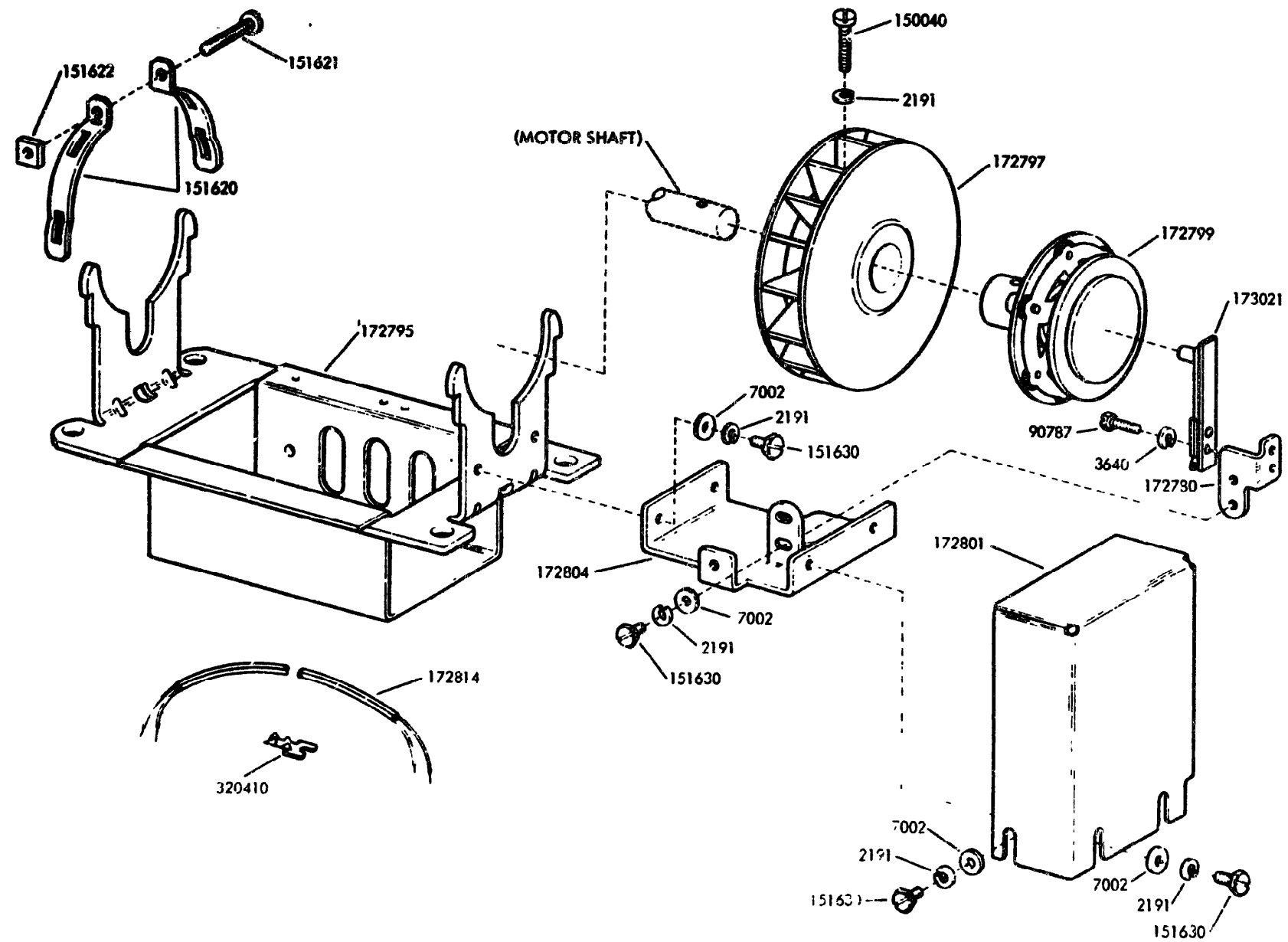

FIGURE 12. SYNCHRONOUS MOTOR MOUNTING WITH CENTRIFUGAL SWITCH ASSEMBLY

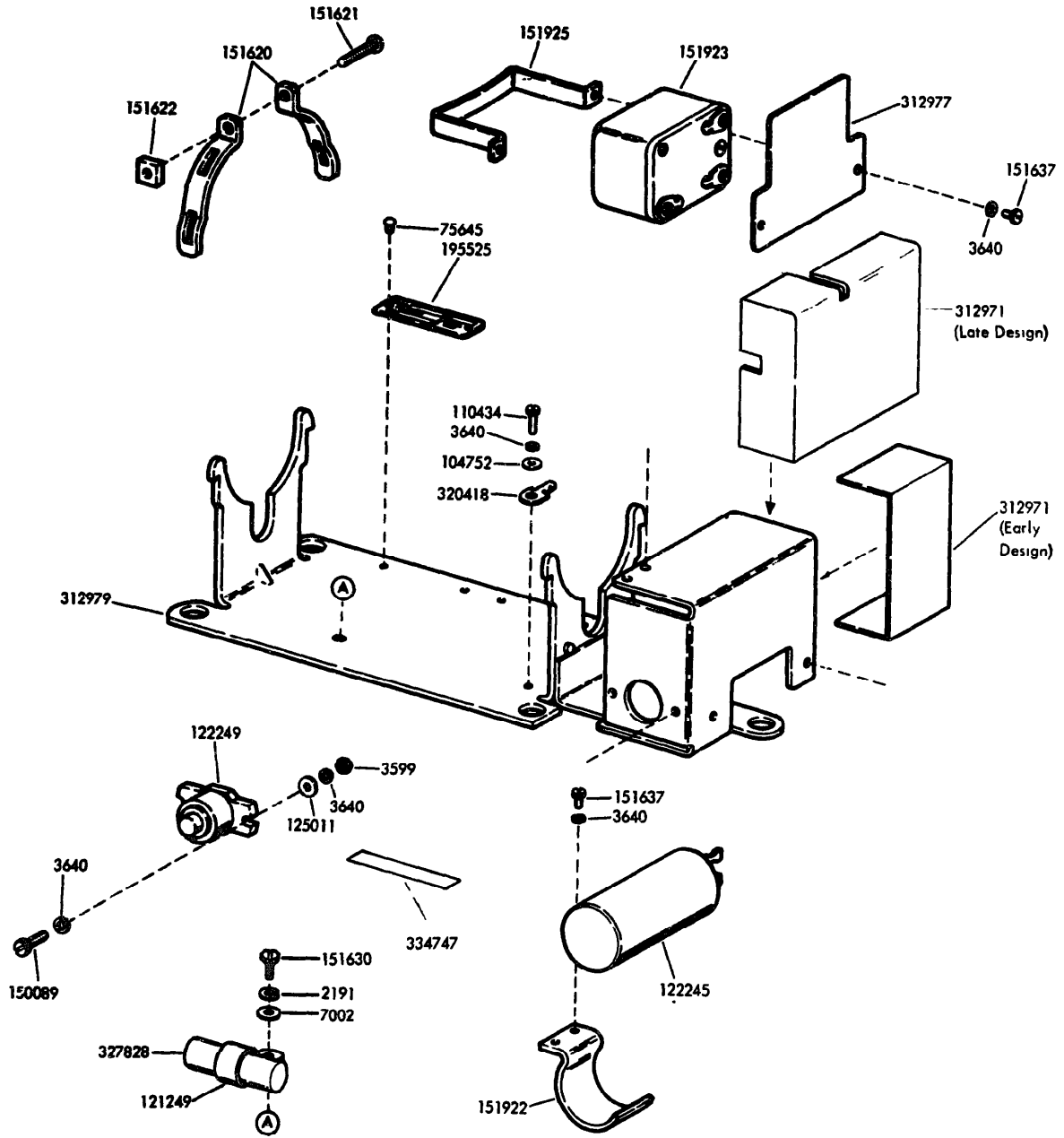

FIGURE 13. RELAY AND CAPACITOR MOUNTING (SYNCHRONOUS)

SERIES MOTOR UNITS

Teletype Code	Motor Assembly	Motor Bracket	Container	Lid	Nipple	Capacitor	Resistor	Electrical Noise Suppressor	Cable Assembly	Jumper
LMU4	150701	152046	152039	152040	152067	161579	161580	161578	152059	91228 (2-1/2" lg. w/320420 and 320422 Terminals) 162684 (2-3/4" lg. w/164479 Terminal) 162685 (4" lg. w/164479 Terminal)
LMU6	150701	150976				161579	161580			91228 (2-1/2" lg. w/320420 and 320422 Terminals) 162684 (2-3/4" lg. w/164479 Terminal) 163268 (6-1/2" lg. White w/164479 Terminal) 163269 (2" lg. w/164479 Terminal)
LMU10	150701	152046	152039	152040	152067	161579	161580	161578	152059	91228 (2-1/2" lg. w/320420 and 320422 Terminals) 162684 (2-3/4" lg. w/164479 Terminal) 162685 (4" lg. w/164479 Terminal)
LMU13	163272	150976				161579	161580			91228 (2-1/2" lg. w/320420 and 320422 Terminals) 162684 (2-3/4" lg. w/164479 Terminal) 163268 (6-1/2" lg. White w/164479 Terminal) 163269 (2" lg. w/164479 Terminal)
LMU14	161577	152046	152039	152040	152067	161579	161580	161578	152059	91228 (2-1/2" lg. w/320420 and 320422 Terminals) 162684 (2-3/4" lg. w/164479 Terminal) 162685 (4" lg. w/164479 Terminal)
LMU23	164758	173751				173003	173004			91228 (2-1/2" lg. w/320420 and 320422 Terminals)
LMU28	179100	152046	179105	179106	179282	161579	179103	161578	179283	91228 (2-1/2" lg. w/320420 and 320422 Terminals)
LMU29	179190	152046	179420	179424	152067	179421	173004	179422	152059	91228 (2-1/2" lg. w/320420 and 320422 Terminals)
LMU32	194060	152046	194057	179424	194063	161579	179103	161578	152059	91228 (2-1/2" lg. w/320420 and 320422 Terminals)
LMU39	161577	152046	179420	179424	152067	161579	179103	161578	152059	91228 (2-1/2" lg. w/320420 and 320422 Terminals)
LMU41	150701	152046	179420	179424	152067	161579	179103	161578	152059	91228 (2-1/2" lg. w/320420 and 320422 Terminals)
LMU47	150701	152046	179420	179424	152067	161579	179103		152059	91228 (2-1/2" lg. w/320420 and 320422 Terminals)
LMU57	324111	152046								91228 (2-1/2" lg. w/320420 and 320422 Terminals)
LMU60	324111	150976						161578	152059	91228 (2-1/2" lg. w/320420 and 320422 Terminals)
LMU61	321580	150976						161578	152059	91228 (2-1/2" lg. w/320420 and 320422 Terminals)
LMU63	324111	152046	179105	179106	179282			161578	179283	91228 (2-1/2" lg. w/320420 and 320422 Terminals)
LMU64	324111	150976						161578	152059	91228 (2-1/2" lg. w/320420 and 320422 Terminals)
YMU5	321580	152046								91228 (2-1/2" lg. w/320420 and 320422 Terminals)

FIGURE 14. SERIES MOTOR CROSS-REFERENCE CHART





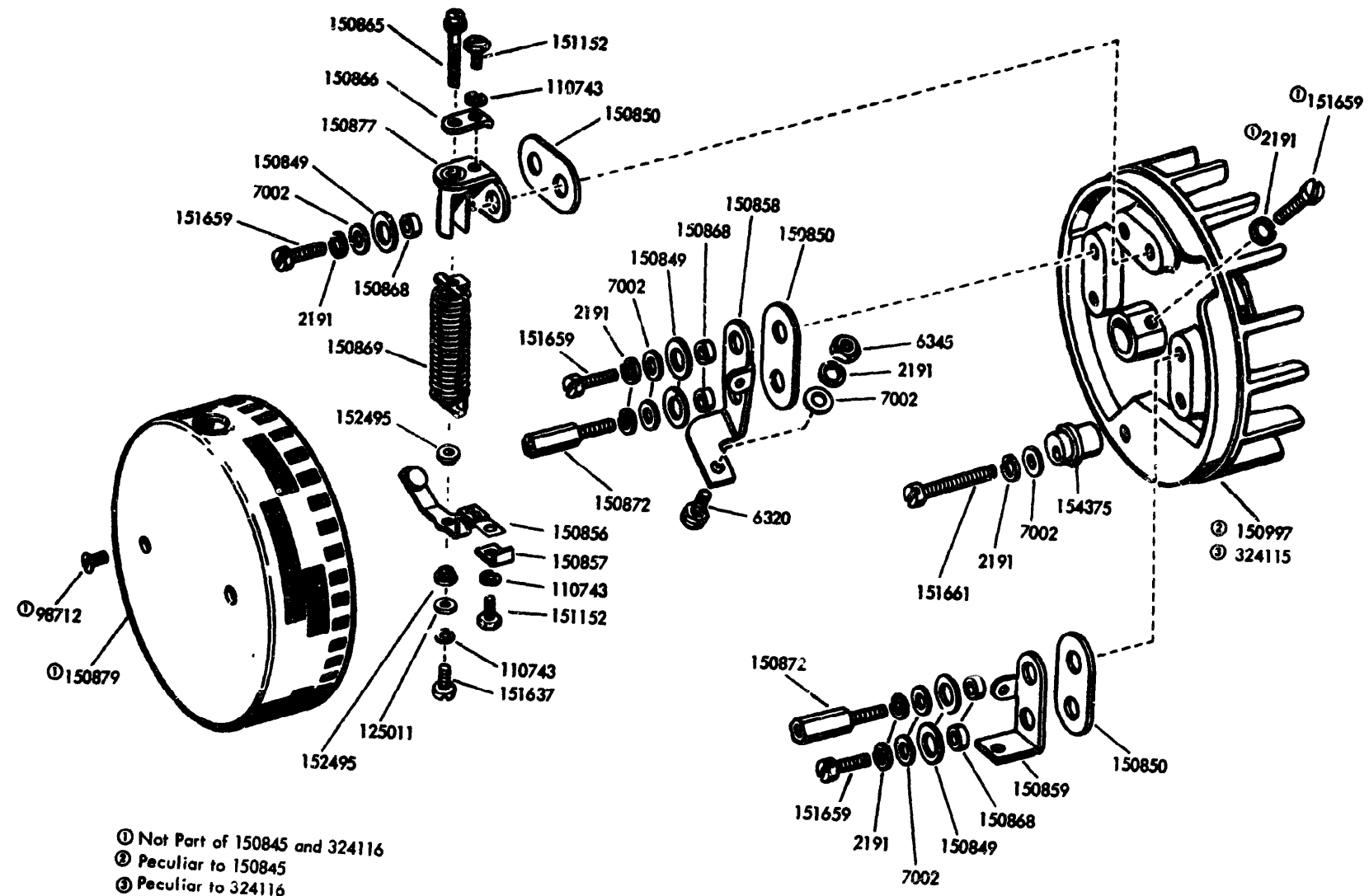

FIGURE 17. 150845 AND 324116 GOVERNORS ASSEMBLIES





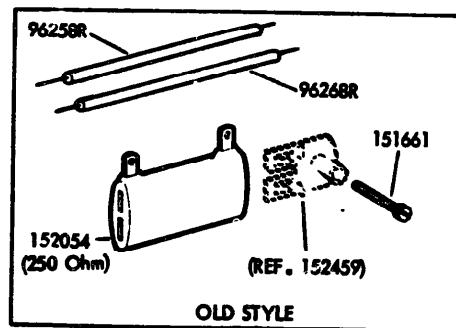
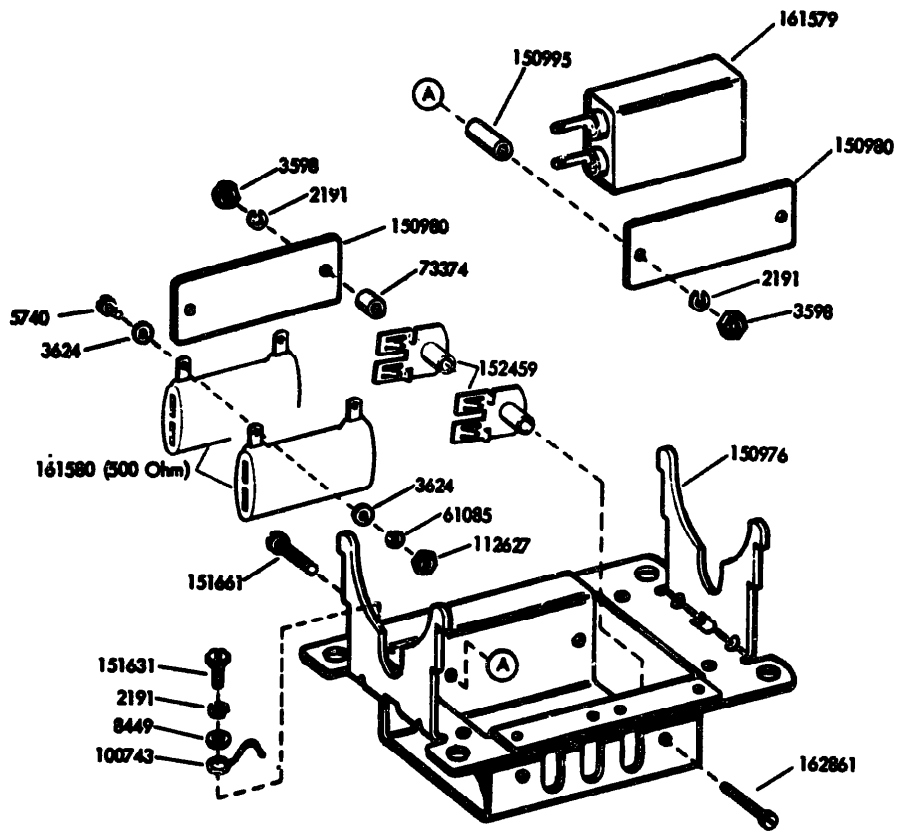

FIGURE 19. SERIES MOTOR MOUNTING PARTS

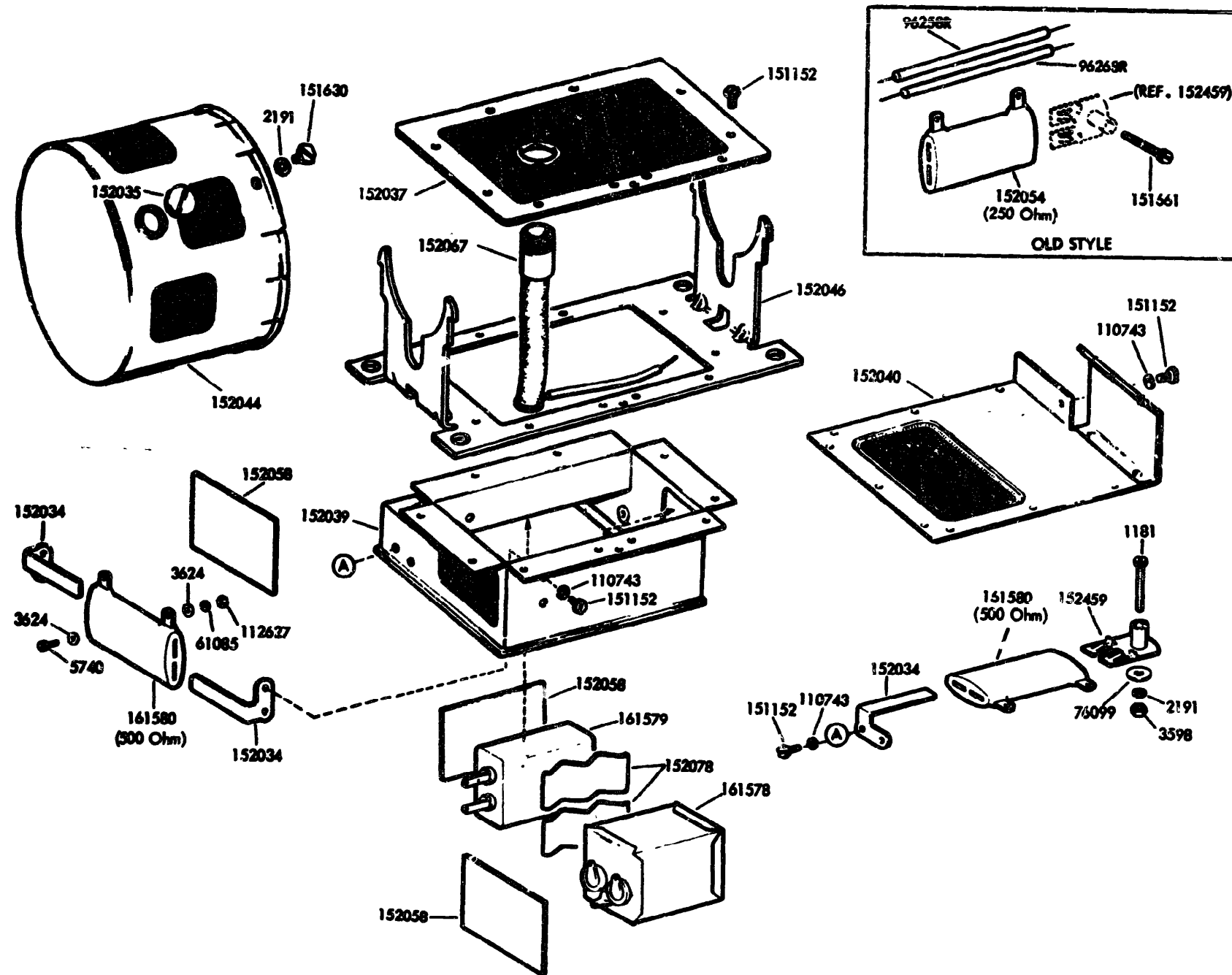

FIGURE 20. SERIES AND MOTOR MOUNTING PARTS WITH RF SUPPRESSION

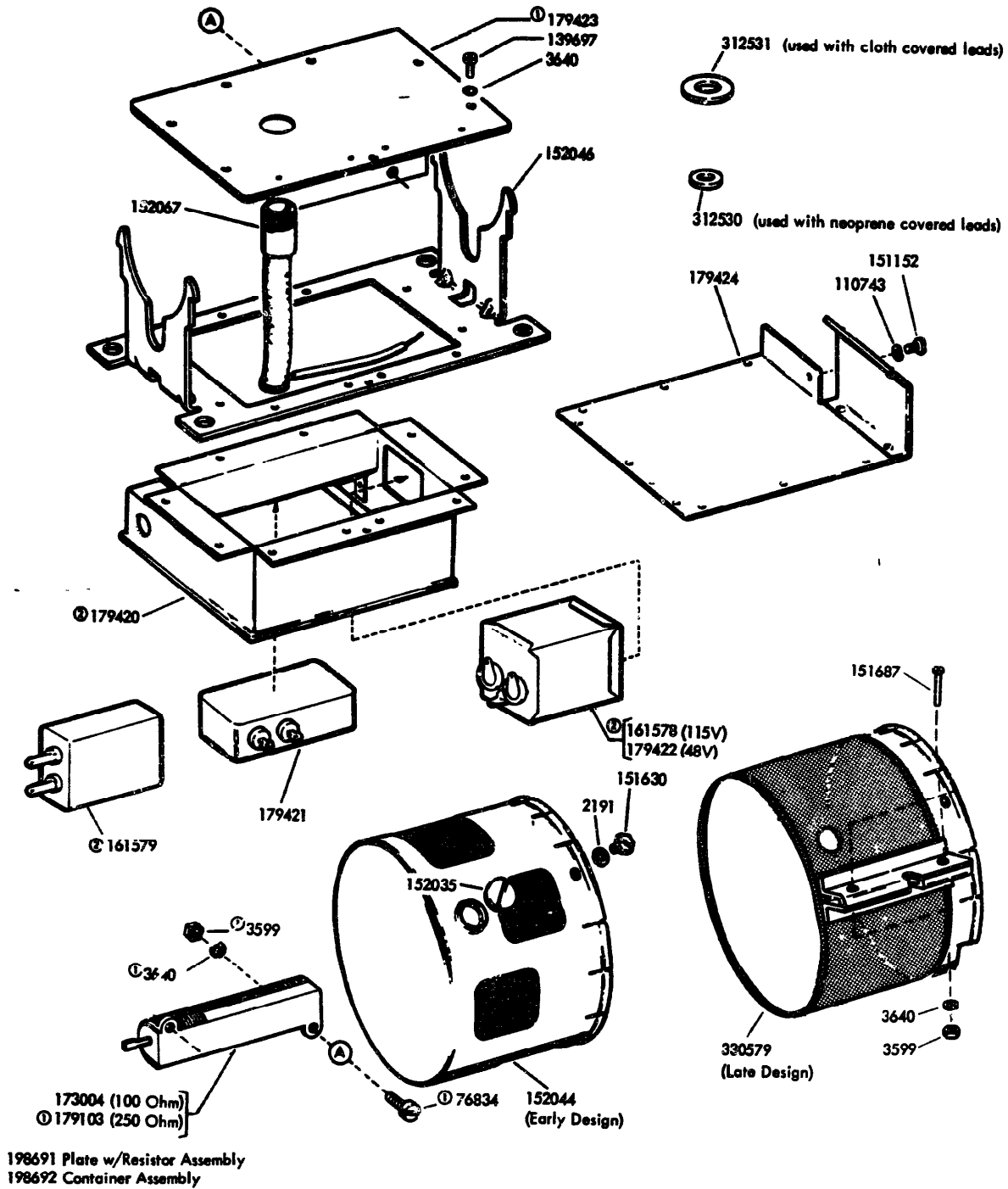

FIGURE 21. SERIES MOTOR MOUNTING PARTS WITH RF SUPPRESSION

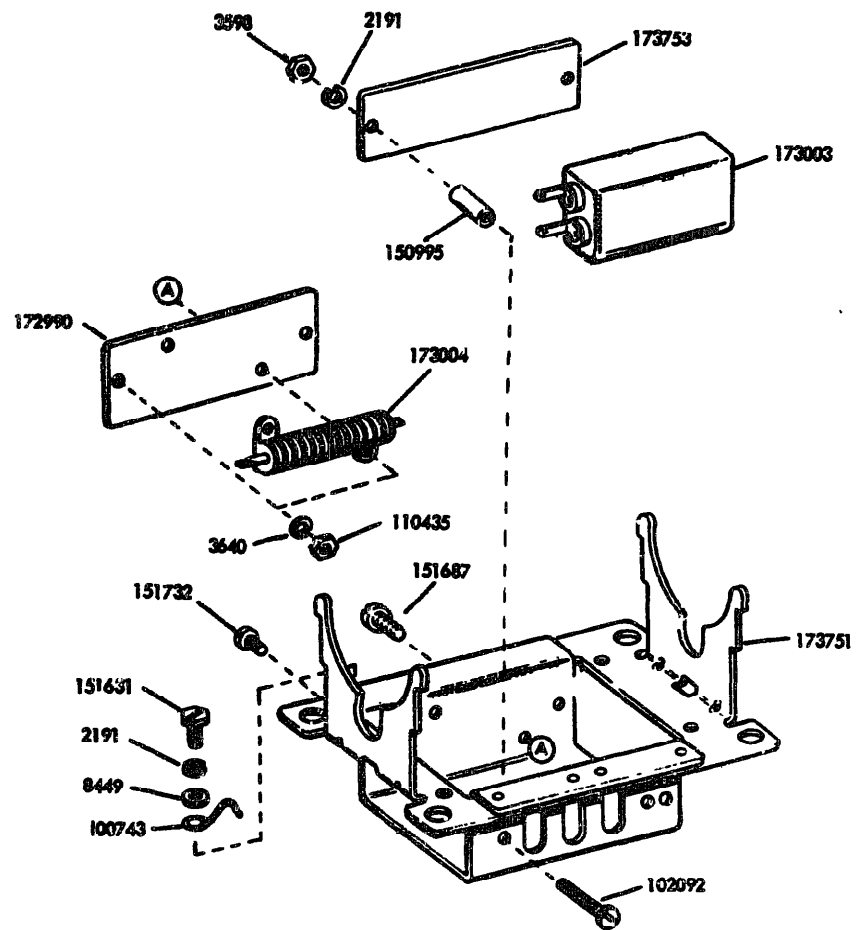

FIGURE 22. SERIES MOTOR MOUNTING PARTS

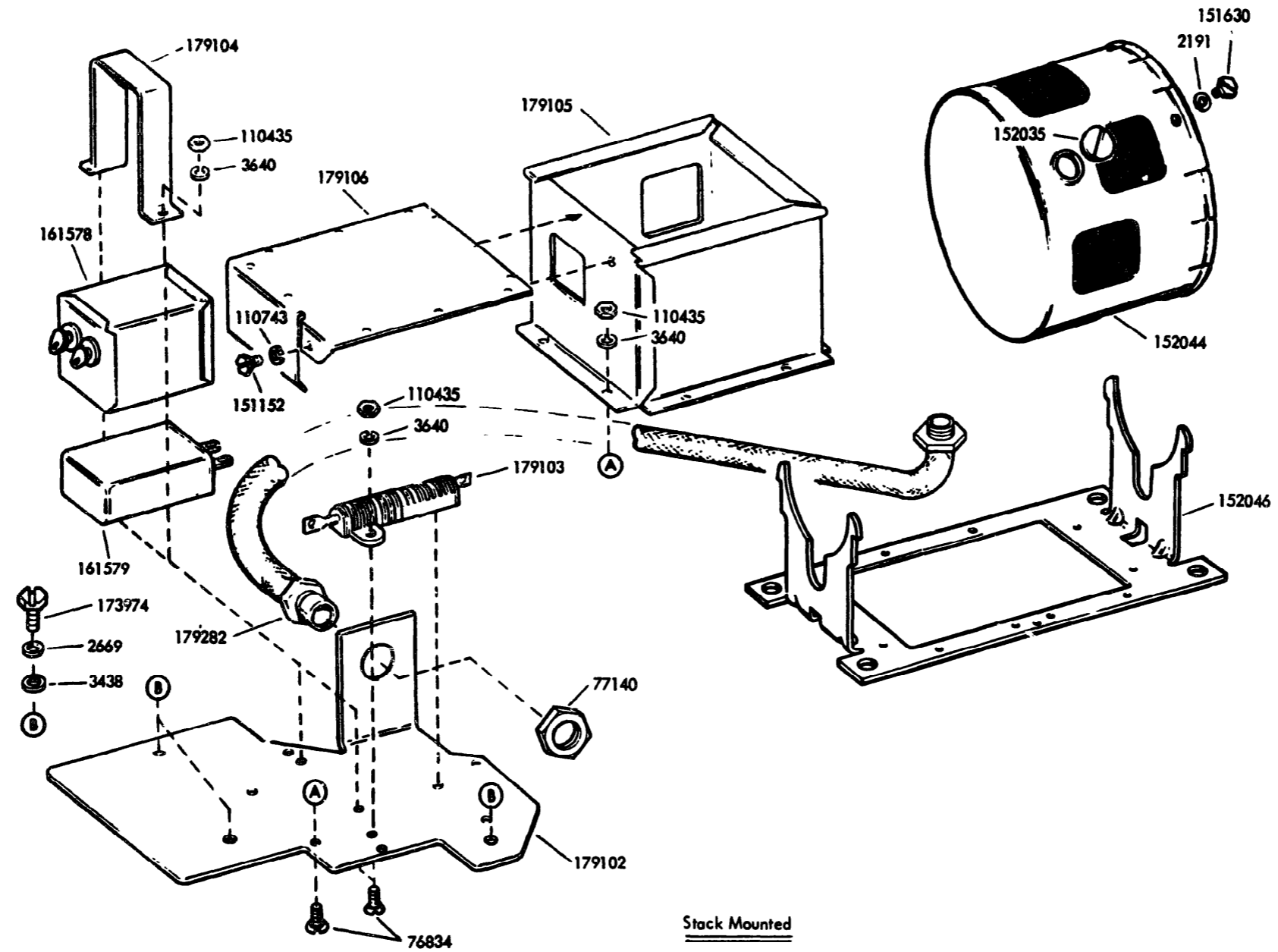

FIGURE 23. SERIES AND MOTOR MOUNTING PARTS WITH RF SUPPRESSION

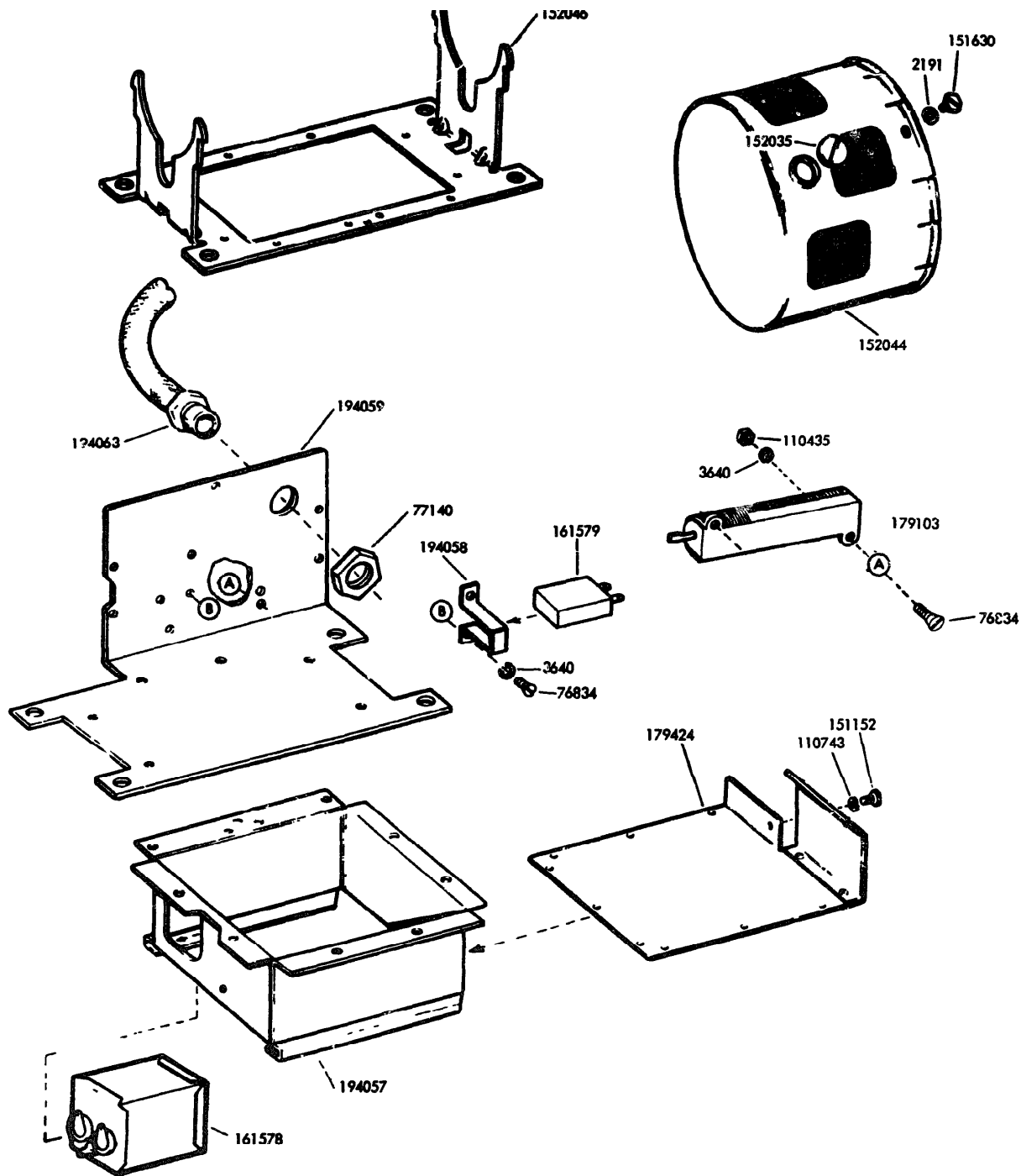

FIGURE 24. SERIES MOTOR MOUNTING PARTS WITH RF SUPPRESSION

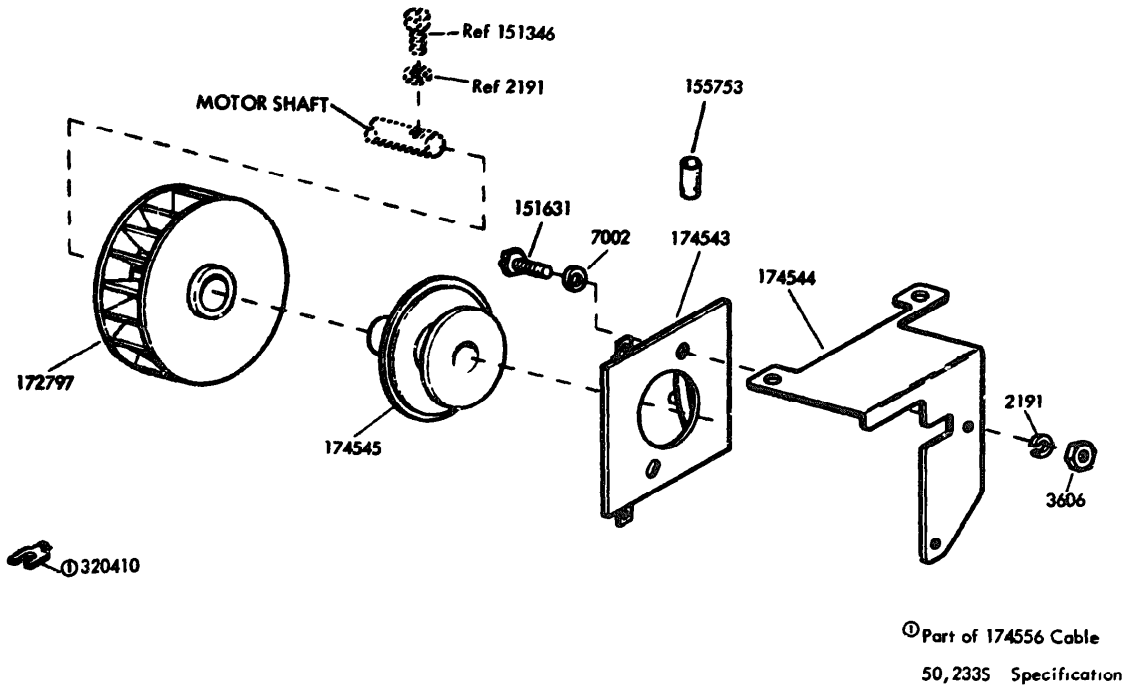

FIGURE 25. 174546 MODIFICATION KIT TO PROVIDE MOTOR RUNNING CONTACTS

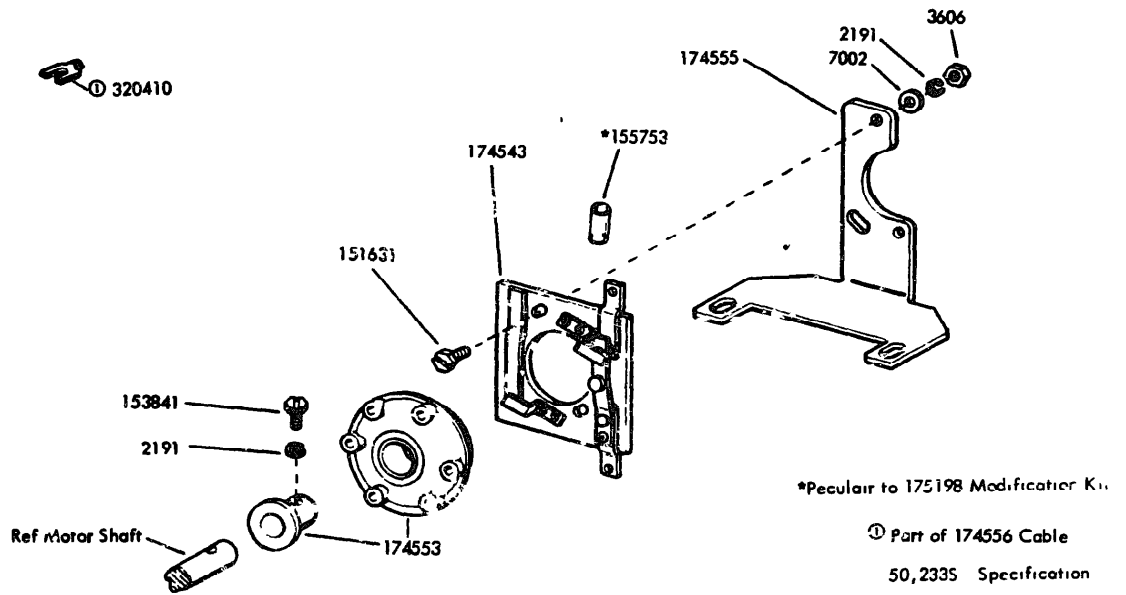
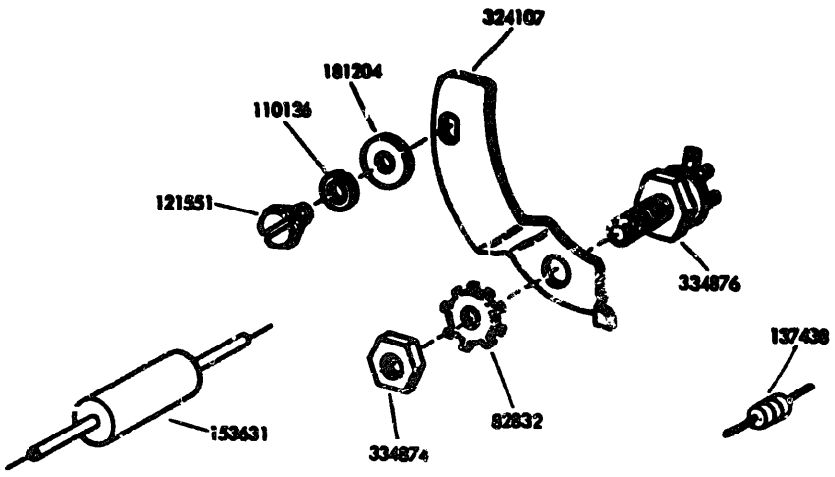

FIGURE 26. 174551 (LESS CABLE) 175198 (WITH CABLE) MODIFICATION KITS TO PROVIDE MOTOR RUNNING CONTACTS



Note: Part of 321580 and 324111  
Motor Assemblies

FIGURE 27. TRIAC SWITCH

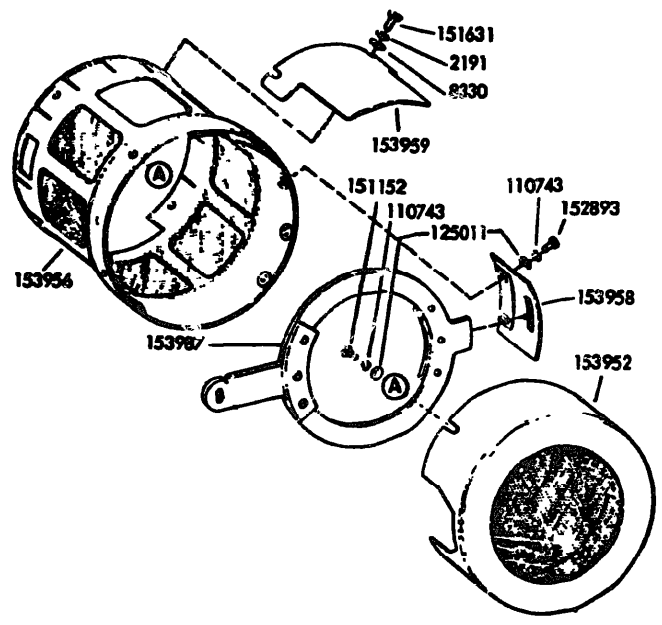

FIGURE 28. MOTOR COVERS



**MODIFICATION KITS**  
(Parts are illustrated on the pages indicated)

Modification Kit-Number	Part Number	Description	Quantity	Figure Number	Specification Number
<b>198693</b>	<b>Modification Kit to Convert and LMU14 to and LMU39</b>				<b>50,376S</b>
	3640	Lockwasher	7	19	
	75646	Screw, Drive	4		
	122233	Capacitor Assembly	1	13	
	139697	Screw, 4-40 x 9/32 Fil	7	19	
	320410	Terminal	1	13	
	152067	Nipple	1	19	
	161576	Stator, Motor	1	13	
	179424	Lid w/Insulator	1	19	
	198691	Plate w/Resistor Assembly	1	19	
	198692	Container Assembly	1	19	
	309431	Plate, Code (LMU39X)	1		
	312530	Washer, Textolite	1	19	
	312531	Washer, Fiber	1	19	
<b>304739</b>	<b>Modification Kit to Convert an LMU46 to an LMU41.</b>				<b>50,376S</b>
	2191	Lockwasher	4	19	
	3640	Lockwasher	8	19	
	75646	Screw, Drive	4		
	110743	Lockwasher	1	19	
	122221	Stator, Motor	1	13	
	122233	Capacitor Assembly	1	13	
	139697	Screw, 4-40 x 9/32 Fil	7	19	
	151152	Screw, 4-40 x 3/16 Hex	1	19	
	320410	Terminal	1	13	
	151630	Screw, 6-40 x 1/4 Hex	4	19	
	152035	Plug	1	19	
	152044	Cover	1	19	
	152046	Bracket w/Cradle, Motor	1	19	
	152067	Nipple	1	19	
	179424	Lid w/Insulator	1	19	
	198691	Plate w/Resistor Assembly	1	19	
	198692	Container Assembly	1	19	
	309432	Plate, Code (LMU41X)	1		
	312530	Washer, Textolite	1	19	
	312531	Washer, Fiber	1	19	
<b>306708</b>	<b>Modification Kit to Convert an LMU10 to an LMU47.</b>				<b>50,376S</b>
	3640	Lockwasher	7	19	
	75646	Screw, Drive	4		
	122221	Stator, Motor	1	13	
	122233	Capacitor Assembly	1	13	
	139697	Screw, 4-40 x 9/32 Fil	7	19	
	320410	Terminal	1	13	
	152067	Nipple	1	19	
	179424	Lid w/Insulator	1	19	
	198691	Plate w/Resistor Assembly	1	19	
	198692	Container Assembly	1	19	
	309433	Plate, Code (LMU47X)	1		
	312530	Washer, Textolite	1	19	
	312531	Washer, Fiber	1	19	
<b>306709</b>	<b>Modification Kit to Convert an LMU4 to an LMU41.</b>				<b>50,376S</b>
	3640	Lockwasher	7	19	
	75646	Screw, Drive	4		
	122221	Stator, Motor	1	13	
	122233	Capacitor Assembly	1	13	
	139697	Screw, 4-40 x 9/32 Fil	7	19	
	320410	Terminal	1	13	
	152067	Nipple	1	19	
	179424	Lid w/Insulator	1	19	

**MODIFICATION KITS (Continued)**  
**(Parts are illustrated on the pages indicated)**

Modification Kit-Number	Part Number	Description	Quantity	Figure Number	Specification Text
	198691	<b>Plate w/Resistor Assembly</b>	<b>1</b>	19	
	198692	<b>Container Assembly</b>	<b>1</b>	19	
	309432	<b>Plate, Code (LMU41X)</b>	<b>1</b>		
	312530	<b>Washer, Textolite</b>	<b>1</b>	19	
	312531	<b>Washer, Fiber</b>	<b>1</b>	19	

NUMERICAL INDEX

Part Number	Description and Page Number	Part Number	Description and Page Number	Part Number	Description and Page Number
1030	Screw, Shoulder 6-40 19	90787	Screw, 4-40 x 3/8 Hex 13	122233	Capacitor Assembly 16,28
1181	Screw, 6-40 x 11/16 Fil 21	91228	Strap, 2-1/2" Braided 5,15	122245	Capacitor, 43 to 48 Mfd 3,5,7,8,9,14
1298	Screw, 8-32 x 1/4 Fil 6	91229	Strap, 2" Braided 5	122249	Switch, Thermosiotic 3,5, 7,8,9,14
2034	Washer, Flat 12	91837	Washer, Insulating 16	122251	Stator, Motor 4
2191	Lockwasher 4,5,6,7,9,12, 13,14,16 to 28	92260	Lockwasher 16	122252	Shield Assembly, End 4
2263	Nut, 8-32 Hex 4	93118	Lockwasher 19	122253	Shield Assembly, End 16
2449	Lockwasher 9	93984	Lockwasher 12	123769	Field Assembly, End 16
2669	Lockwasher 24	96258R	Jumper, 3" Red 20,21	125011	Field, Motor 4
3438	Washer, Flat 24	96262R	Jumper, 4" Red 3	125143	Washer, Flat 5,6,8,9,11, 14,18,19,27
3598	Nut, 6-40 Hex 5,6,9,12, 20,21,23	96264R	Jumper, 5" Red 3	125802	Screw, 6-32 x 3/8 Flat 16
3599	Nut, 4-40 Hex 14,19,22	96268R	Jumper, 7" Red 20,21	125802	Washer, Flat 19
3606	Nut, 6-40 Hex 19,26	96274R	Jumper, 10" Red 3	128874	Rotor, Motor 4
3624	Washer, Flat 20,21	98642	Lockwasher 16	137438	Resistor, 100 Ohm 27
3640	Lockwasher 5,6,7,8,9,11, 12,13,14,19,22,23,24,25, 28	98712	Screw, 4-40 x 1/4 Flat 18	139697	Screw, 4-40 x 9/32 Fil 22,28
3646	Lockwasher 6	98718	Washer, Flat 6	142589	Bracket w/Cradle, Motor 3,11
3949	Spacer, .160" Thk 12	100743	Clamp, Cable 20,23	146997	Cap, Bushing 12
5740	Screw, 2-56 x 1/4 Fil 20,21	102092	Screw, 6-40 x 1-17/32 Rd 23	150040	Screw, 6-40 x 5/8 Fil 4,13
6320	Screw, 6-32 Contact 18,19	102203	Bushing 9	150089	Screw, 4-40 x 1/2 Fil 14
6345	Nut, 6-32 Hex 16,18,19	104752	Washer, Flat 7,14	150701	Motor, 115V AC Series 15,16
7002	Washer, Flat 5,6,7,12,13, 14,17,18,19,26	104807	Washer, Flat 19	150845	Governor Assembly 1,18
8330	Washer, Flat 19,27	110126	Lockwasher 27	150846	Holder Assembly, Left
8449	Spacer, .094" Thk 12,20, 23	110434	Screw, 4-40 x 3/16 Fil 7,14	150847	Brush 17
36273	Washer, Flat 5,7	110435	Nut, 4-40 Hex 19,23,24,25	150849	Holder Assembly, Right
42823	Washer, Flat 19	110475	Screw, 2-64 x 5/64 Rd 19	150849	Brush 17
61085	Lockwasher 20,21	110743	Lockwasher 18,19,21,22, 24,25,27,28	150849	Washer, Insulating 18,19
71999	Spring, Motor Thrust 4,16	111017	Screw, 6-40 x 5/16 Fil 19	150850	Insulator, .031" Thk 18,19
73374	Spacer, .250" 20	111062	Terminal 16	150856	Arm, Contact 18,19
75645	Screw, No. 0 x 1/8 Drive 14	112627	Nut, 2-56 Hex 20,21	150857	Clamp 18,19
75646	Screw, No. 0 x 3/16 Drive 28	119223	Screw, 4-40 x 1-15/32 Fil 5,11	150858	Bracket, Contact 18,19
76099	Washer, Flat 21	119648	Ring, Retaining 19	150859	Bracket, Mounting 18,19
76461	Washer, Flat 19	119651	Ring, Retaining 19	150865	Screw, 4-40 Clamping 18
76834	Screw, 4-40 x 3/8 Flat 22,24,25	121249	Clamp, 5/8 ID Cable 14	150866	Clamp 18
77140	Nut, Lock 9/16 - 32 Hex 24,25	121551	Screw, 8-32 x 1/4 Hex 27	150868	Bushing, Insulating 18,19
82392	Shim, .004" Thk 19	122200	Shield Assembly, End 16	150869	Spring 18
82832	Lockwasher 27	122201	Rearing, Ball 4,16	150872	Stud 18
86736	Plate, Clamping 19	122202	Stud 16	150873	Collar 9,17
87334	Washer, Insulating 5,6,8, 9,11	122204	Cap, Brush 16	150877	Bracket, Guide 18
90560	Washer, Flat 19	122205	Brush w/Spring 16	150879	Cover, Governor 18
		122206	Holder, Brush 16	150880	Spring, Governor Brush 17
		122208	Washer, Flat 16	150881	Spring, Governor Brush 17
		122210	Armature, Motor 16	150882	Brush, Contact 17
		122211	Washer, Pull 4,16	150884	Mounting, Brush 17
		122220	Oiler, Ball 4,16	150885	Plate, Brush 17
		122221	Stator 16,28		
		122229	Bolt, 8-32 x 4-11/16 Fil 4		

**NUMERICAL INDEX (Continued)**

Part Number	Description and Page Number	Part Number	Description and Page Number	Part Number	Description and Page Number
150886	Plate, Clamp 17	151924	Insulator, .031" Thk 3,5,9	153965	Bracket 19
150976	Bracket, w/Cradle, Motor 5,15,20	151925	Clamp 3,5,8,9,11,14	153966	Gear Assembly 19
150980	Plate, Clamping 20	151926	Nut, 4-40 Spl 5,6,8,11	153967	Gear, 28 T 19
150995	Bushing 20,23	151927	Cable w/Terminals 3,6	153968	Gear Assembly 19
150997	Fan, Governor 18	151939	Grommet, Rubber 6	153976	Gear, 32 T 19
151152	Screw, 4-40 x 3/16 Hex 18,19,21,22,24,25,27,28	152034	Bracket, Resistor 21	153977	Worm 19
151346	Screw, 6-40 x 3/8 Fil 4, 17,26	152035	Plug 21,22,24,25,28	153979	Post 19
151453	Nut, 10-32 Hex 16	152037	Cover 21	153987	Brake, Slide 27
151455	Spring, Helical Clip 16	152039	Container 15,21	154375	Sacktop 18,19
151620	Strap, Motor Mounting 5,6,8,9,11,12,13,14,16	152044	Lid 15,21	154628	Governor Assembly 1,19
151621	Screw, 6-32 x 3/4 Rd 5,6, 8,9,11,12,13,14,16	152046	Cover 21,22,24,25,28	154674	Gear, 20 T 19
151622	Nut, 6-32 Sq 5,6,8,9,11, 12,13,14,16	152046	Bracket w/Cradle, Motor 15,21,22,24,25,28	154676	Disc Assembly 19
151630	Screw, 6-40 x 1/4 Hex 7, 12,13,14,16,21,22,24,25, 28	152054	Resistor, 250 Ohm 20,21	154580	Bearing, Roller 19
151631	Screw, 6-40 x 5/16 Hex 20,23,26,27	152058	Separato 21	154684	Insulator 19
151632	Screw, 6-40 x 3/8 Hex 6	152059	Cable w/Terminals 15	154685	Fan Assembly 18
151637	Screw, 4-40 x 1/4 Fil 5, 6,8,9,11,12,14,18	152067	Nipple 15,21,22,28	154693	Bracket 19
151642	Screw, 6-40 x 3/4 Fil 4,17	152078	Spring, Separator 21	155585	Bearing, Ball 19
151657	Screw, 6-40 x 1/4 Fil 5,6,17	152297	Washer, Bearing 4	155593	Bearing, Ball 19
151658	Screw, 6-40 x 5/16 Fil 17	152426	Nut, 6-40 Hex Self-Locking 12	155594	Screw, 4-40 Shoulder 19
151659	Screw, 6-40 x 1/2 Fil 12, 18,19	152459	Bracket, Mounting 20,21	155595	Motor, Synchronous 3,4
151661	Screw, 6-40 x 1" Fil 17, 18,20,21	152495	Bushing 18,19	155600	Bracket 19
151686	Screw, 4-40 x 3/8 Fil 5,6,8,11,19	152893	Screw, 4-40 x 1/4 Hex 12,27	155601	Plate, Gear Train 19
151687	Screw, 4-40 x 7/16 Fil 9,22,23	153030	Mount, Vibration 4,10,16	155602	Gear, 28 T 19
151692	Screw, 6-40 x 3/16 Fil 5,6,19	153031	Bushing, Lead 16	155603	Gear, 28 T 19
151693	Screw, 6-40 x 9/16 Fil 19	153049	Washer, Insulating 4	155605	Bearing, Ball 19
151721	Screw, 6-40 x 3/4 Hex 9	153101	Grommet, Rubber 16	155611	Ring, Bearing 19
151732	Screw, 4-40 x 11/32 Fil 23	153102	Screw, Set 8-32 16	155613	Gear, 28 T 19
151795	Motor, Synchronous 3,4	153103	Screw, 4-40 Self-Tapping 16	155752	Sleeve, 5/64 ID x 1/2 Lg Insulating 7
151920	Plate, Mounting 3,5,6	153114	Jumper, 8-1/2" Black 16	155753*	Sleeve, 1/8 ID x 1/2" Lg Insulating 26
151922	Clamp 3,5,6,8,9,11,14	153342	Screw, 6-40 x 15/16 Hex 19	156875	Screw, 6-40 x 5/32 Fil 5,7
151923	Relay, Motor Starting 3, 5,7,8,9,14	153535	Screw, 6-40 x 15/16 Hex 19	156936	Screw, 1/4-32 x 5/16 Hex 9
		153336	Screw, 6-40 Shoulder 19	157987	Washer, Insulating 19
		153631	Gear Assembly 19	159739	Motor, Synchronous 3,4
		153839	Network, Spark Suppression 27	160298	Plate, Mounting 5
		153841	Screw, 6-40 x 5/8 Hex 12	160299	Capacitor, 226 MFD 3,5
		153885	Screw, 6-40 x 9/16 Hex 26	160300	Clamp 5
		153952	Spring Assembly 19	160301	Plate, Insulating 5
		153956	Cover, Motor 27	160302	Plate, Nut 3,5,11
		153958	Cover 27	160303	Relay 3,5
		153959	Guide Plate 27	160304	Switch, Thermostatic 3,5
		153962	Coverplate 27	160305	Rotor, Motor 4
		153963	Clamp 19	160306	Stator, Motor 4
		153964	Diak 19	161099	Cable w/Terminals 3
			Counterweight 19	161575	Armature, Motor 16
				161576	Stator, Motor 16,28
				161577	Motor, 115V AC Series 15,16

NUMERICAL INDEX (Continued)

Part Number	Description and Page Number	Part Number	Description and Page Number	Part Number	Description and Page Number
161578	<b>Suppressor, Noise 15,21, 22,24,25</b>	172780	Bracket, Contact Mounting 13	179104	<b>Bracket, Clamp 24</b>
161579	<b>Capacitor, .5 MFD 15,20, 21,22,24,25</b>	172795	Bracket w/Cradle, Motor 3,13	179105	<b>Container 15,24</b>
161580	<b>Resistor, 500 Ohm 15,20,21</b>	172797	Fan 13,26	179106	<b>Lid w/Insulator 15,24</b>
161984	<b>Motor, AC Synchronous 3,10</b>	172799	Switch, Centrifugal 13	179190	<b>Motor, 48V DC Series 15, 16</b>
162072	<b>Capacitor, 88 to 108 MFD 3,11,12</b>	172801	Cover, Switch 13	179282	<b>Nipple 15,24</b>
162196	<b>Insulator 3,11</b>	172804	Plate, Adapter 13	179283	<b>Cable w/Terminals 15</b>
162360	<b>Fuse, SL-BL .8 Amp 12</b>	172814	Cable w/Terminals 13	179420	<b>Container 15,22</b>
162464	<b>Stator, Motor 10</b>	172902	Nut, 6-32 Hex 10	179421	<b>Capacitor, 1 MFD 15,22</b>
162466	<b>Shield, Rear End 10</b>	172990	Plate 23	179422	<b>Suppressor, Noise 15,22</b>
162467	<b>Shield, Front End 10</b>	173003	Capacitor, 1 MFD 15,23	179423	<b>Plate w/Bracket 22</b>
162469	<b>Washer, Spring 10</b>	173004	Resistor, 100 Ohm 15,22, 23	179424	<b>Lid w/Insulator 15,22,25, 28</b>
162482	<b>Bolt, 6-32 x 3-1/2 Fil 10</b>	173021	Contact, Spring 13	181204	<b>Washer, Flat 27</b>
162684	<b>Jumper, 2-3/4" White 15</b>	173425	Relay, Motor Starting 3, 11,12	192226	<b>Bracket, Capacitor Mounting 12</b>
162685	<b>Jumper, 4" White 15</b>	173518	Modification Kit 2	193181	<b>Cable w/Terminals 3</b>
162861	<b>Screw, 6-40 x 1-7/16 Fil 20</b>	173687	Fan, Motor 5	193236	<b>Cable w/Terminals 3</b>
162910	<b>Insulator 3,11</b>	173751	Bracket w/Cradle, Motor 15,23	193781	<b>Switch, Thermostatic 3,5,8,9</b>
162911	<b>Cable w/Terminals 3</b>	173753	Plate 23	194057	<b>Container 15,25</b>
163268	<b>Jumper, 6-1/2" White 15</b>	173974	Screw, 10-32 x 5/16 Hex 24	194058	<b>Clamp 25</b>
163269	<b>Jumper, 2" White 15</b>	174471	Switch, Thermostatic 3, 11,12	194059	<b>Bracket 25</b>
163272	<b>Motor, 115V AC Series 15,16</b>	174543	Switch 26	194060	<b>Motor, 115V AC Series 15, 16</b>
163273	<b>Shield Assembly, End 16</b>	174544	Bracket 26	194062	<b>Shield Assembly, End 16</b>
163799	<b>Bracket 12</b>	174545	Rotor 26	194063	<b>Nipple 15,25</b>
164479	<b>Terminal 15</b>	174545	Modification Kit 1,26	194897	<b>Bracket w/Cradle, Motor 3,9</b>
164603	<b>Insulator 3,8</b>	174546	Modification Kit 1,26	194899	<b>Cable w/Terminals 3</b>
164612	<b>Bracket w/Cradle, Motor 3,8</b>	174551	Modification Kit 1,26	194924	<b>Motor, 115V AC Synchronous 3,10</b>
164756	<b>Stator, Motor 16</b>	174553	Rotor 26	195143	<b>Capacitor, 7 MFD 12</b>
164757	<b>Armature, Motor 16</b>	174555	Bracket, Switch 26	195172	<b>Capacitor, Motor Start 64 to 77 MFD 3,12</b>
164758	<b>Motor, 48V DC Series 15, 16</b>	174556	Cable w/Terminals 26	195173	<b>Relay 3,12</b>
164890	<b>Bearing, Ball 10</b>	175198	Modification Kit 1,26	195178	<b>Cable w/Terminals 3</b>
164891	<b>Shim, .032" Thk 10</b>	176064	Plate, Nut 12	195214	<b>Stator 10</b>
164892	<b>Shim, .018" Thk 10</b>	176111	Duct 12	195525	<b>Plate, Identification 14</b>
164893	<b>Collar, Thrust 10</b>	176137	Jumper, 9-1/4" Black 3	196794	<b>Insulator 3,8</b>
164894	<b>Shim, .018" Thk 10</b>	176947	Plate w/Pads 3,9	196795	<b>Block, Mounting 8</b>
164962	<b>Bracket 11,12</b>	176948	Bracket w/Cradle, Motor 39	196830	<b>Motor, Synchronous 3,4</b>
170631	<b>Holder, Fuse 12</b>	178500	Motor, AC Synchronous 3,4	196831	<b>Stator, Motor 4</b>
170764	<b>Motor, AC Synchronous 3,4</b>	179010	Bracket, Relay 11	196839	<b>Bracket w/Cradle, Motor 3,8</b>
171702	<b>Clamp 3,12</b>	179016	Cable w/Terminal 3	198691	<b>Plate w/Resistor Assembly 22,28,29</b>
171703	<b>Clamp 3,12</b>	179100	Motor, 115V AC Series 15,16	198692	<b>Container Assembly 22,28, 29</b>
171704	<b>Insulator 3,12</b>	179101	Shield Assembly, End 16	198693	<b>Modification Kit 28</b>
171749	<b>Bracket, w/Cradle, Motor 3,12</b>	179102	Plate, Mounting 24		
171810	<b>Cable w/Terminals 3</b>	179103	Resistor, 250 Ohm 15,22, 24,25		

**NUMERICAL INDEX (Continued)**

Part Number	Description and Page Number	Part Number	Description and Page Number	Part Number	Description and Page Number
199718	<b>Motor, 115V AC 50 Hertz Synchronous 3,4</b>	307281	<b>Switch, Thermostatic 3,6</b>	320410	<b>Terminal, Spade Type 3, 13,16,26,28</b>
199719	<b>Rotor, Motor 4</b>	309431	<b>Plate, Code 28</b>	320418	<b>Terminal, Ring Type 3,5, 6,7,14</b>
199720	<b>Stator, Motor 4</b>	309432	<b>Plate, Code 28,29</b>	320420	<b>Terminal, Ring Type 5,15</b>
199721	<b>Bolt, 8-32 x 5-13/16 Fl 4</b>	309433	<b>Plate, Code 28</b>	320422	<b>Terminal, Ring Type 5,15</b>
304537	<b>Bracket 3,6</b>	310295	<b>Motor, Synchronous 3,10</b>	321580	<b>Motor Series 15,16,27</b>
304538	<b>Bracket 3,6</b>	310341	<b>Insulator 3,9</b>	324107	<b>Bracket 27</b>
304739	<b>Modification Kit 28</b>	312269	<b>Shield, End 16</b>	324111	<b>Motor Assembly 15,16,27</b>
304792	<b>Relay 3,6</b>	312270	<b>Stator 16</b>	324112	<b>Stator 16</b>
304793	<b>Capacitor, 161 to 193 MFD 3,6</b>	312530	<b>Washer, Textolite 22,28, 29</b>	324113	<b>Shield Assembly, End 16</b>
305658	<b>Spring 3,7</b>	312531	<b>Washer, Fiber 22,28,29</b>	324115	<b>Fan, Governor 18</b>
305659	<b>Insulator 3,7</b>	312573	<b>Jumper, 6" Red 3,6</b>	324116	<b>Governor Assembly 1,18</b>
305660	<b>Plate, Mounting 3,7</b>	312574	<b>Jumper, 6" Black 3,6</b>	327828	<b>Filter w/Network 14</b>
305661	<b>Bracket w/Cradle, Motor 3,7</b>	312971	<b>Shield 14</b>	330564	<b>Rotor 10</b>
306063	<b>Motor, 230V AC Synchronous 3,4</b>	312977	<b>Insulator 3,14</b>	330565	<b>Rotor 10</b>
306320	<b>Cable Assembly 3</b>	312979	<b>Bracket w/Cradle, Motor 3,14</b>	330579	<b>Screen w/Brackets 22</b>
306708	<b>Modification Kit 28</b>	320269	<b>Switch, Thermostatic 3,5</b>	332865	<b>Fan 4</b>
306709	<b>Modification Kit 28</b>	320270	<b>Capacitor, 15 to 18 MFD 3,5</b>	664747	<b>Label 14</b>
		320271	<b>Relay, Motor Starting 3,5</b>	334874	<b>Nut, 1/4-28 Hex 27</b>
		320272	<b>Stator 4</b>	334876	<b>Switch 27</b>
				334877	<b>Switch 3</b>

**END**

**11-19-82**

**DATE**



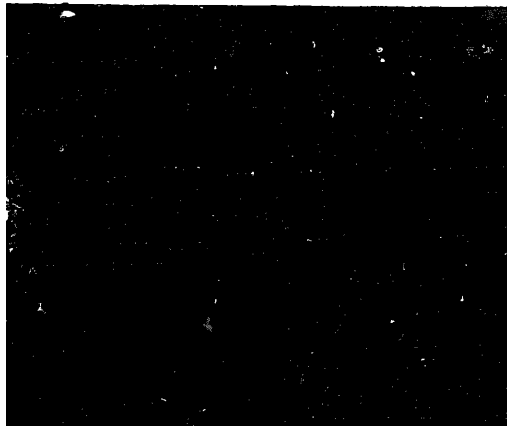



DEPARTMENT OF THE ARMY  
MICROFORM  
TEST TARGET

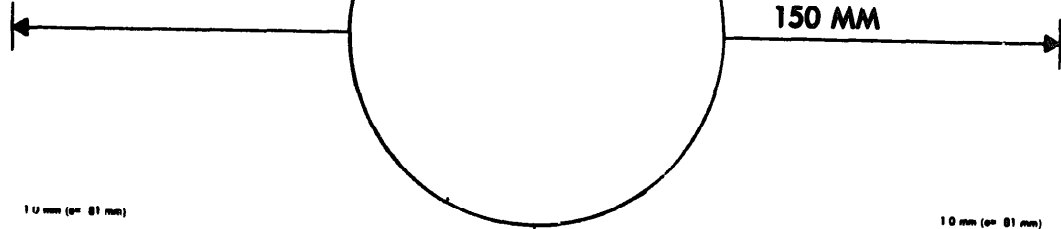
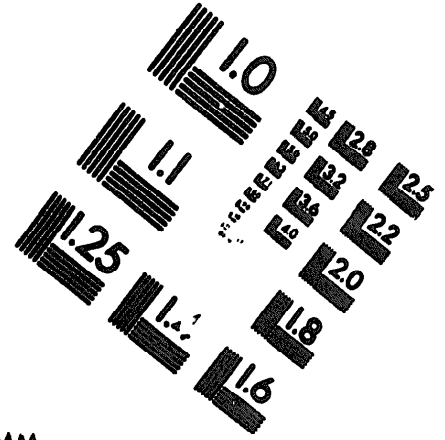
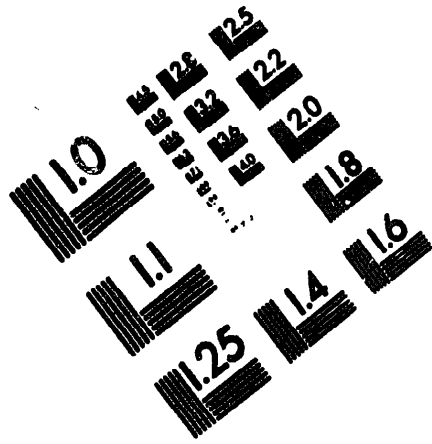

1.0 mm (e= 81 mm)  
ABCDEFGHIJKLMN OPQRSTUVWXYZ 1234567890  
abcdefghijklmnopqrstuvwxyz \$%&' /%# 1/2 1/4 3/4 —=+ x&@\*

1.5 mm (e= 109 mm)  
ABCDEFGHIJKLMN OPQRSTUVWXYZ 1234567890  
abcdefghijklmnopqrstuvwxyz \$%&' /%# 1/2 1/4 3/4 —=+ x&@\*

2.0 mm (e= 1.37 mm)  
ABCDEFGHIJKLMN OPQRSTUVWXYZ  
abcdefghijklmnopqrstuvwxyz  
1234567890 \$%&' /%# 1/2 1/4 3/4 —=+ x&@\*

2.5 mm (e= 1.77 mm)  
ABCDEFGHIJKLMN OPQRSTUVWXYZ  
abcdefghijklmnopqrstuvwxyz  
1234567890 \$%&' /%# 1/2 1/4 3/4 —=+ x&@\*

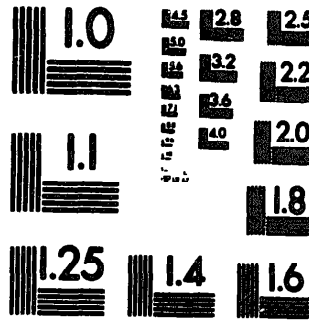

1.0 mm (e= 81 mm)  
ABCDEFGHIJKLMN OPQRSTUVWXYZ 1234567890  
abcdefghijklmnopqrstuvwxyz \$%&' /%# 1/2 1/4 3/4 —=+ x&@\*

1.5 mm (e= 109 mm)  
ABCDEFGHIJKLMN OPQRSTUVWXYZ 1234567890  
abcdefghijklmnopqrstuvwxyz \$%&' /%# 1/2 1/4 3/4 —=+ x&@\*

2.0 mm (e= 1.37 mm)  
ABCDEFGHIJKLMN OPQRSTUVWXYZ  
abcdefghijklmnopqrstuvwxyz  
1234567890 \$%&' /%# 1/2 1/4 3/4 —=+ x&@\*

2.5 mm (e= 1.77 mm)  
ABCDEFGHIJKLMN OPQRSTUVWXYZ  
abcdefghijklmnopqrstuvwxyz  
1234567890 \$%&' /%# 1/2 1/4 3/4 —=+ x&@\*

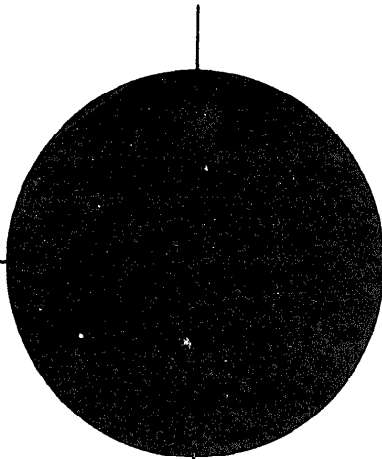
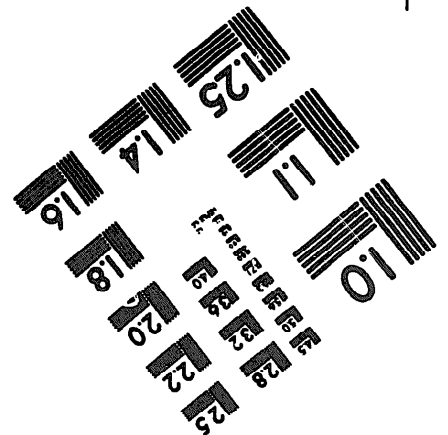
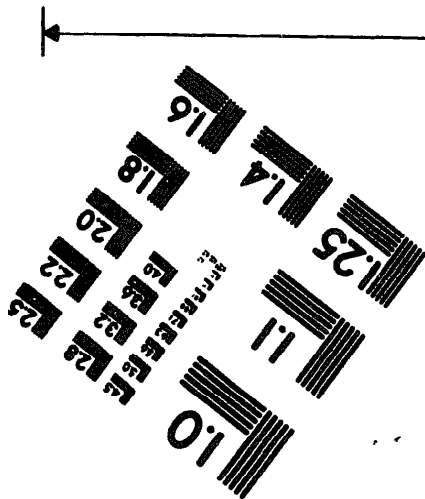

250 MM